



BERNINA 570 QE

User Manual

Table of Contents

IMPORTANT SAFETY INSTRUCTIONS	9	2.5 Spool Pin	33
Important Information	11	Retractable Spool Pin	33
1 My BERNINA	13	Horizontal Spool Pin	34
1.1 Introduction	13	2.6 Feed Dog	35
1.2 BERNINA Quality Control	13	Adjusting the Feed Dog	35
1.3 Welcome to the World of BERNINA	13	2.7 Slide-on Table	35
1.4 Overview Machine	15	Using the Slide-on Table	35
Overview Front Controls	15	Using the Seam Guide	35
Overview - Front	16	2.8 Presser Foot	36
Overview - Side Panel	17	Adjusting the Presser Foot Position via the Knee Lifter of the Free Hand System	36
Overview - Back Panel	18	Adjusting the Presser Foot Position via the Button «Presser Foot Up/Down»	36
1.5 Supplied Accessories	19	Changing the Presser Foot	36
Overview Accessories Machine	19	Selecting the Presser Foot in the User Interface	36
Overview Presser Feet	20	Setting the Presser Foot Pressure	37
Accessories Box	22	2.9 Adjusting the Feed Dog	37
1.6 Overview User Interface	22	2.10 Needle and Stitch Plate	37
Overview Functions/Visual Information	22	Changing the Needle	37
Overview System Settings	23	Selecting the Needle in the User Interface	38
Overview Selection Menu Sewing	23	Selecting the Needle Type and the Needle Size	38
Software Operation	23	Adjusting the Needle Position Up/Down	39
1.7 Needle, Thread, Fabric	25	Adjusting the Needle Position Left/Right	39
Overview Needles	26	Needle Stop Up/Down (Permanent)	39
Example for Needle Description	28	Changing the Stitch Plate	39
Thread Selection	28	Selecting the Stitch Plate in the User Interface	40
Needle/Thread Combination	29	2.11 Threading	40
2 Sewing Preparation	30	Threading the Upper Thread	40
2.1 Before Using the Machine for the First Time	30	Threading the Twin Needle	43
2.2 Accessories Box	30	Threading the Triple Needle	43
Removing and Mounting the Accessory Box from Machine	30	Winding the Bobbin Thread	44
Storing Accessory	30	Threading the Bobbin Thread	45
2.3 Connection and Switching On	31	Indicating Fill Level of Bobbin Thread	47
Connecting the Foot Control	31	3 Setup Program	48
Connecting the Machine	31	3.1 Sewing Settings	48
Attaching the Knee Lifter of the Free Hand System	31	Adjusting the Upper Thread Tension	48
Fixing the Touch Screen Pen	32	Adjusting the Maximum Sewing Speed	48
Switching the Machine On	32	Setting Securing Stitches (Smart Secure)	48
2.4 Foot Control	32	Adjusting the Hovering Height of the Presser Foot	48
Regulating the Speed via the Foot Control	32	Programming the Button «Pattern End»	49
Activate/Deactivate Additional Function	33	Programming the Button «Thread Cutter»	49
		Adjusting the Presser Foot Position with Needle Stop Down	50
		Programming the Button «Quick Reverse»	50
		Programming the Foot Control	50



3.2	Embroidery Settings	51	Programming the Stitch Counter Function	65
	Adjusting the Upper Thread Tension	51	Sewing Stitch Patterns Using the Triple Stitch	66
	Adjusting the Maximum Embroidering Speed	51	Quick Reverse	66
	Setting the Embroidery Design Position when Opening	52	Permanent Quick Reverse	66
	Calibrating the Embroidery Hoop	52	Backstepping	66
	Entering the Fabric Thickness	52	5.6 Combining Stitch Patterns	66
	Activating/Deactivating the Function Thread Away	53	Overview Combi Mode	66
	Programming Securing Stitches (Smart Secure)	53	Creating Stitch Pattern Combinations	67
	Adjusting the Thread Cut	54	Saving a Stitch Pattern Combination	67
	Changing the Measuring Unit	54	Loading a Stitch Pattern Combination	67
3.3	Selecting Personal Settings	55	Overwriting a Stitch Pattern Combination	67
3.4	Monitoring Functions	55	Deleting a Stitch Pattern Combination	67
	Activating the Upper Thread Indicator	55	Editing a Single Stitch Pattern	68
	Activating the Bobbin Thread Indicator	55	Deleting a Single Stitch Pattern	68
3.5	Activating the Audio Signals	56	Adding a Single Stitch Pattern	68
3.6	Machine Settings	56	Adapting the Stitch Pattern length and Stitch Pattern Width	69
	Selecting a Language	56	Mirroring a Stitch Pattern Combination	70
	Adjusting the Brightness of the Display	56	Stitch Pattern Combination Subdivider 1	70
	Adjusting the Sewing Light	57	Stitch Pattern Combination Subdivider 2	70
	Reviewing the Total Number of Stitches	57	Securing a Stitch Pattern Combination	71
	Registering Details of the Dealer	57	Programming Pattern Repeat	71
	Saving Service Data	58	5.7 Administering Stitch Patterns	71
	Back to Basic Setting	58	Saving Settings of Stitch Patterns	71
	Deleting User Data	58	Saving Stitch Patterns in Personal Memory	71
	Deleting Designs on the BERNINA USB Stick	59	Overwriting Stitch Patterns from the Personal Memory	72
	Calibrating the Buttonhole Foot #3A	59	Loading Stitch Patterns from the Personal Memory	72
	Packing the Embroidery Module	59	Deleting Stitch Patterns from the Personal Memory	72
4	System Settings	61	Saving Stitch Patterns on the BERNINA USB Stick	72
4.1	Calling Up the Tutorial	61	Uploading a Stitch Pattern from the BERNINA USB Stick	72
4.2	Calling Up the Creative Consultant	61	Deleting Stitch Patterns from the BERNINA USB Stick ..	73
4.3	Using eco Mode	61	5.8 Securing Stitches	73
4.4	Calling Up the Help	61	Securing via the Icon «Securing»	73
4.5	Cancelling any Alterations with «clr»	61	Securing with the Button «Pattern End»	73
5	Creative Sewing	62	5.9 Height Compensation of Uneven Layers	74
5.1	Overview Selection Menu Sewing	62	5.10 Sewing Corners	74
	Selecting a Stitch Pattern	62	6 Practical Stitches	75
5.2	BERNINA Dual Feed	62	6.1 Overview Practical Stitches	75
5.3	Regulating the Speed	63	6.2 Sewing Straight Stitch	77
5.4	Adjusting the Upper Thread Tension	63	6.3 Securing with the Automatic Securing Program	78
5.5	Editing Stitch Patterns	64	6.4 Sewing in the Zipper	78
	Changing the Stitch Width	64	6.5 Sewing Both Sides of the Zipper from Bottom to Top	79
	Changing the Stitch Length	64	6.6 Sewing Triple Straight Stitch	80
	Correcting the Balance	64	6.7 Sewing Triple Zigzag	80
	Programming Pattern Repeat	65	6.8 Manual Darning	81
	Mirror Image of Stitch Patterns	65		
	Edit Stitch Pattern Length	65		

6.9	Automatic Darning	82	9.10	Sewing a Buttonhole Automatically	105
6.10	Reinforced Darning, Automatic	83	9.11	Programming the Heirloom Buttonhole	105
6.11	Reinforced Darning	84	9.12	Sewing the manual 7-step buttonhole with the Buttonhole Foot #3C	106
6.12	Finishing Edges	84	9.13	Sewing the Manual 5-step Buttonhole with the Buttonhole Foot #3C	106
6.13	Sewing Double Overlock	85	9.14	Cutting the Buttonhole Open with the Seam Ripper	107
6.14	Narrow Edgestitching	85	9.15	Cutting Open Buttonholes with the Buttonhole Cutter (Optional Accessory)	108
6.15	Wide Edgestitching	85	9.16	Sewing on a Button	108
6.16	Edgestitching Using the Seam Guide	86	9.17	Sewing Eyelets	109
6.17	Sewing Hem Edges	86	10	Quilting	110
6.18	Sewing Blind Hems	87	10.1	Overview Quilt Stitches	110
6.19	Sewing Visible Hems	88	10.2	Quilting, Securing Program	111
6.20	Sewing Flat Joining Seams	88	10.3	Sewing Handlook Quilt Stitches	111
6.21	Sewing Basting Stitches	89	10.4	Guiding the Quilt Work Freely	112
7	Decorative Stitches	90	11	BERNINA Stitch Regulator (BSR)	113
7.1	Overview Decorative Stitches	90	11.1	BSR Mode 1	113
7.2	Bobbin-Play	91	11.2	BSR Mode 2	113
7.3	Sewing Cross Stitches	92	11.3	BSR Function with Straight Stitch No. 1	113
7.4	Pintucks	92	11.4	BSR Function with Zigzag No. 2	113
	Pintucks	92	11.5	Sewing Preparations for Quilting	113
	Overview Pintuck Feet	93		Attach the BSR Presser Foot	113
	Working with Cord	94		Changing the Presser Foot	114
	Sewing Pintucks	95	11.6	Using the BSR Mode	114
8	Alphabets	96	11.7	Securing Stitches	115
8.1	Overview Alphabet	96		Securing in BSR1 Mode with the Button «Start/Stop» .	115
8.2	Creating Lettering	96		Securing in BSR2 Mode	115
8.3	Alter Font Size	97	12	My BERNINA Embroidery	116
9	Buttonholes	98	12.1	Overview Embroidery Module	116
9.1	Overview Buttonholes	98	12.2	Supplied Accessories Embroidery Module	116
9.2	Making Use of the Height Compensation Tool	99		Overview Accessory Embroidery Module	116
9.3	Using the Compensation Plate	99	12.3	Overview User Interface	117
9.4	Marking Buttonholes	100		Overview Functions/Visual Information	117
9.5	Cord	101		Overview System Settings	118
	Using Cord with the Buttonhole Foot with Slide #3A ...	101		Overview Selection Menu Embroidery	118
	Using cord with the Buttonhole Foot #3C	102	12.4	Important Embroidery Information	118
9.6	Sewing a Test Sample	103		Upper Thread	118
9.7	Determining the Buttonhole Slit Width	103		Bobbin Thread	119
9.8	Determining the Buttonhole Length with the Buttonhole Foot with Slide #3A	104		Selecting the Embroidery File Format	119
9.9	Determining the buttonhole length with Buttonhole Foot #3C	104		Embroidery Test	119
				The Size of the Embroidery Design	119



Embroidering Designs by Third-party Providers	120	15.3	Checking the Embroidery Time and the Embroidery Design Size	133
Underlay Stitches	120	15.4	Regulating the Speed	133
Satin or Leaf Stich	120	15.5	Editing the Embroidery Design	133
Step Stitch	120		Overview Editing Embroidery Design	133
Connecting Stitches	121		Scaling Up the Embroidery Design View	134
13 Embroidery Preparation	122		Downsizing the Embroidery Design	134
13.1 Attaching the Embroidery Module	122		Moving the Embroidery Design View	134
13.2 Removing the Embroidery Module	122		Moving the Embroidery Design in Enlarged View	135
13.3 Preparing the Machine	122		Moving the Embroidery Design	135
Lower the Feed-dog	122		Rotating the Embroidery Design	135
Selecting the Embroidery Design	123		Altering the Embroidery Design Size Proportionally	135
13.4 Embroidery Foot	123		Altering the Embroidery Design Size Disproportionally	136
Attaching the Embroidery Foot	123		Mirroring Embroidery Designs	137
Selecting the Stitch Plate in the User Interface	124		Changing the Stitch Type	137
13.5 Needle and Stitch Plate	124		Altering the Stitch Density	137
Inserting the Embroidery Needle	124		Checking the Size and the Position of the Embroidery Design	138
Selecting the Embroidery Needle in the User Interface	124		Duplicating the Embroidery Design	138
Selecting Needle Type and Needle Size	125		Deleting an Embroidery Design	139
Adjusting the Needle Position Up/Down	125	15.6	Combining Embroidery Designs	139
Attaching the Stitch Plate	125		Combining Embroidery Designs	139
Selecting the Stitch Plate in the User Interface	126		Deleting a Single Embroidery Design	139
Thread-up Command	126		Duplicating a Combination	139
13.6 Embroidery Hoops	127	15.7	Creating Lettering	140
Overview Embroidery Hoop Selection	127		Overview Embroidery Alphabets	140
Selecting the Embroidery Hoop	127		Creating Lettering	141
Tear-away Stabilizers	127		Editing the Lettering	141
Cut-away Stabilizers	127	15.8	Changing the Colors of the Embroidery Design	142
Using Adhesive Spray	127		Overview Changing the Color	142
Using Spray Starch	128		Changing the Colors	142
Using Iron-on Interfacing	128		Changing the Thread Brand	142
Using Paper-backed Adhesive Stabilizer	128	15.9	Embroidering the Embroidery Design	143
Using Water-soluble Stabilizer	128		Overview Embroidery Menu	143
Preparing the Embroidery Hoop	128		Adding Basting Stitches	143
Attaching the Hoop	129		Moving the Hoop	143
Overview Embroidery Functions	130		Embroidery Sequence Control when the Thread Breaks	143
Centering the Needle to the Embroidery Hoop	130		Cutting Connecting Stitches	144
Move Hoop to the Back	130		Reducing Color Changes	144
Moving the Module for the Sewing Mode	130		Multi-colored Embroidery Design On/Off	144
Grid On/Off	131		Color Indication	144
Locating the Center of the Embroidery Design	131	15.10	Freearm Embroidery	144
Virtual Positioning of the Embroidery Hoop	131	15.11	Administering Embroidery Designs	145
14 Setup Program	132		Administering Embroidery Designs	145
14.1 Adjusting the Embroidery Settings in the Setup Program	132		Saving Embroidery Designs in the Personal Memory	145
15 Creative Embroidering	133		Saving the Embroidery Design on the BERNINA USB Stick	146
15.1 Overview Embroidering	133		Overwriting the Embroidery Design in the Personal Memory	146
15.2 Selecting and Changing the Embroidery Design	133			

Overwriting the Embroidery Design on the BERNINA USB Stick	146	Children	179
Importing Stitch Patterns	146	Borders and Lace	182
Loading an Embroidery Design from the Personal Memory	147	Seasons	184
Loading an Embroidery Design from the BERNINA USB Stick	147	Sport and Hobbies	188
Deleting an Embroidery Design from the Personal Memory	147	Animals	189
Deleting an Embroidery Design from the BERNINA USB Stick	147	Frames	190
		DesignWorks	192
16 Embroidery	148	Index	194
16.1 Embroidering via the Button «Start/Stop»	148		
16.2 Increasing the Embroidery Speed	148		
16.3 Adjusting the Upper Thread Tension	148		
16.4 Embroidering via the Foot Control	149		
17 Care and Maintenance	150		
17.1 Firmware	150		
Checking the Firmware Version	150		
Updating Firmware	150		
Recovering Saved Data	150		
17.2 Machine	151		
Cleaning the Display	151		
Cleaning the Feed Dog	151		
Cleaning the Hook	152		
Lubricating the Hook	152		
Cleaning the Thread Catcher	154		
18 Errors and Faults	155		
18.1 Error Messages	155		
18.2 Troubleshooting	159		
19 Storage and Disposal	163		
19.1 Storing the Machine	163		
19.2 Dispose of the Machine	163		
20 Technical Data	164		
21 Overview Stitch Patterns	165		
21.1 Overview Stitch Patterns	165		
Practical Stitches	165		
Buttonholes	165		
Decorative Stitches	165		
Quilt Stitches	168		
21.2 Overview Embroidery Designs	169		
Editing the Embroidery Design	169		
Quilt Designs	169		
Embellishment	173		
Flowers	177		



IMPORTANT SAFETY INSTRUCTIONS

Please be aware of the following basic safety instructions when using your machine. Before using this machine, read instruction manual carefully.

DANGER

To protect against electric shock, the following instructions must be observed.

- Never leave the machine unattended when it is connected to the power supply.
- Immediately after use and before cleaning, switch off the machine and disconnect the power cable from the outlet.

In order to protect against injury, the following instructions must be adhered to.

- Do not look directly into the LED lamp with optical instruments (e. g. magnifying glass).
- If the LED lamp is damaged or defective, have the LED lamp checked or repaired at your local authorized BERNINA dealer.
- Switch off the machine before working in the needle area.
- Before starting the machine, close all covers.

WARNING

To reduce the risk of burns, fire, electric shock or injury to persons, the following instructions must be observed.

General Facts

- This machine may only be used for the purpose described in this instruction manual.

Working Environment

- Do not use the machine outdoors.

- Only use the machine in dry rooms.
- Do not use the machine in a humid area.
- Do not use the machine in rooms where aerosol products (sprays) are being used.
- Do not use the machine in rooms where oxygen is dispensed.

Technical Condition

- Never use the machine when it is damp.
- Do not use the machine if it is not working properly.
- Do not use the machine if a cable or the plug is damaged.
- Do not use the machine if it has been dropped, damaged or has fallen into water.
- If the machine is damaged or does not work properly, have the machine checked or repaired by your local authorized BERNINA dealer.
- Keep all ventilation openings of the machine and the foot control free of lint, dust and loose cloth.
- Do not use the machine if the ventilation openings are blocked.

Accessories and Supplies

- Only use the accessories recommended by the manufacturer.
- Always use the original BERNINA Stitch Plate.
An incorrect stitch plate can result in needle breakage.
- Use only straight needles of good quality. Bent or damaged needles can cause needle breakage.
- This machine is double-insulated (except for USA, Canada and Japan). Use only identical replacement parts. See instructions for servicing of double-insulated products.
- To lubricate the machine, only use oil recommended by BERNINA.



Safety Instructions

- While operating the machine, all protective inserts must be in place and all covers must be closed.

Appropriate Use

- The machine may be used, cleaned and maintained by children older than eight or by people with reduced physical, sensory or mental capabilities or if there is a lack of experience and knowledge as long as they have been given instructions.
- Furthermore, these persons must be supervised while working with the machine, and/or they must know the safe operation of the machine and be aware of the resulting hazards.
- Children are not allowed to play with the system.
- Special care should be taken when the machine is operated by or in the presence of children.
- Only use the machine with the supplied power cable.
- USA and Canada only: Do not connect power plug NEMA 1-15 to circuits exceeding 150 volt-to-ground.
- Only use this machine with the supplied foot control of type LV-1.
- Do not insert any objects into the openings of the machine.
- Do not place any objects on the foot control.
- While sewing, guide the fabric gently. Pulling and pushing the fabric can cause needle breakage.
- Keep fingers away from all moving parts.
- Special care is required in the needle area.
- For activities in the needle area - such as threading the needle, changing the needle, threading the looper or changing the presser foot - switch off the machine.
- To switch off, set the power switch to «0».

- When protective covers are removed, when the machine is oiled or when other cleaning and maintenance operations mentioned in this instruction manual are carried out, switch off the machine and disconnect the power plug from the outlet.
- Pull the plug out of the outlet by pulling on the plug. Do not pull on the cable.

Safety Signs on the Machine

Sign	Purpose
	<p>Caution; moving parts.</p> <p>To reduce the risk of injury, switch off the machine before maintenance work.</p>



Important Information

Availability of the Instruction Manual

The instruction manual is supplied with the machine.



- Keep the instruction manual safe at a suitable place near the machine to have it at hand in case that you need to look up something.
- If you pass the machine to a third party, always include the instruction manual.
- The latest version of the instruction manual can be downloaded at www.bernina.com

Proper Use

Your BERNINA machine is conceived and designed for private household use. It is intended for sewing fabrics and other materials as described in this instruction manual. Any other use is not considered proper. BERNINA assumes no liability for consequences resulting from improper use.

Equipment and Scope of Delivery

Example images are used in these instructions for the purposes of illustration. The machines shown in the images and the accessories shown therefore do not always match the actual items included with your machine. The supplied accessory can vary depending on the country of delivery. You can acquire any accessories mentioned or shown that are not included in the scope of delivery as optional accessories from a specialist BERNINA dealer. Further accessories can be found at www.bernina.com.

For technical reasons and in order to improve the product, changes may be made to the equipment of the machine and the scope of delivery at any time and without prior notice.

Servicing of Double-insulated Products

In a double-insulated product two systems of insulation are provided instead of grounding. No grounding means is provided on a double-insulated product nor should a means for grounded be added to the product. Servicing a double-insulated product requires extreme care and knowledge of the system and should only be done by qualified service personnel. Replacement parts for a double-insulated product must be identical to the original parts in the product. A double insulated product is marked with the words: «Double-Insulation» or «double-insulated».

 The symbol may also be marked on the product.

Environmental Protection

BERNINA International AG is committed to environmental protection. We strive to minimize the environmental impact of our products by continuously improving product design and our technology of manufacturing.



The machine is labeled with the symbol of the crossed-out wastebin. This means that the machine should not be disposed of in household waste when it is no longer needed. Improper disposal can result in dangerous substances getting into the groundwater and thus into our food chain, damaging our health.

The machine must be returned free of charge to a nearby collection point for waste electrical and electronic equipment or to a collection point for the reuse of the machine. Information on the collection points can be obtained from your local administration. When purchasing a new machine, the dealer is obliged to take back the old machine free of charge and dispose of it properly.

If the machine contains personal data, you are responsible for deleting the data yourself before returning the machine.

Explanation of Symbols

 DANGER

Designates a danger with a high risk which can lead to serious injuries or even death unless it is avoided.

 WARNING

Designates a medium-risk hazard which can lead to serious injuries if not avoided.

 CAUTION

Designates a low-risk hazard which can lead to minor or moderate injuries if not avoided.

NOTICE

Designates a hazard which can lead to material damage if not avoided.



Tips from BERNINA **quilt experts** can be found next to this symbol.



1 My BERNINA

1.1 Introduction

The purposes of your BERNINA 570 QE are sewing, embroidering and quilting. Delicate silk or satin fabrics as well as heavyweight linen, fleece and denim can be sewn without any problems with this machine.

Numerous practical as well as decorative stitches, buttonholes and embroidery designs are at your disposal.

In addition to this instruction manual, following Help Programs are provided at any time to give you useful advice and support how to operate your BERNINA 570 QE.

The **Tutorial** gives information and explanations about various aspects of sewing and embroidering as well as the different stitches.

The **Creative Consultant** informs you about decision support for sewing projects. After entering the choice of fabric and the intended sewing project, suggestions concerning the suitable needle or the appropriate presser foot are displayed.

The **Help Program** provides information about individual stitch patterns, functions and operations in the User Interface.

Further Information



In addition to this instruction manual for your BERNINA 570 QE, further informative print media are enclosed.

The current version of your manual as well as many other information about the machine and the accessories can be found on our website <https://www.bernina.com>

1.2 BERNINA Quality Control

All BERNINA machines are assembled with utmost care and are subjected to an extensive functionality test. The integrated stitch counter therefore indicates that the machine has already sewn stitches, which were performed exclusively for test purposes and quality control. The subsequent thorough cleaning does not exclude the possibility that thread remnants may still be found in the machine.

1.3 Welcome to the World of BERNINA

Made to create, this is the slogan of BERNINA. Not only with our machines do we support you in the implementation of your ideas. In addition to the offers listed below, we offer you lots of suggestions and instructions for your future projects as well as the opportunity to exchange ideas with other sewing, quilting and embroidery enthusiasts. We wish you lots of pleasure.

BERNINA YouTube Channel



On YouTube we offer a wide range of how-to videos and support concerning the most important functions of our machines. You can also find detailed explanations many presser feet, meaning that your projects will be a complete success.

<https://www.youtube.com/BerninaInternational>

Available in English and German.

inspiration – the Sewing Magazine in the Online Shop



Are you looking for ideas, sewing patterns and instructions for great sewing projects? In this case, the BERNINA magazine «inspiration» is exactly what you need. Three times a year, inspiration offers fantastic sewing and embroidery ideas. From seasonal fashion trends to trendy accessories and practical tips to original decorations for your home or cute sewing ideas for children.

The magazine is available in English, German, Dutch, and French.



In our online shop you can purchase "inspiration" as an e-magazine or as a print version, either as individual issues or as a subscription. Furthermore, there are many individual downloadable cutting patterns to discover! Please have a look at <https://www.bernina.com/inspiration>

BERNINA Blog



Refined instructions, free cutting patterns and embroidery designs as well as many new ideas: All this you can find in the weekly blog of BERNINA. Our experts give useful tips and explain step by step how you can achieve the desired result. In the community you can upload your own projects and exchange experiences and ideas with other sewing and embroidering enthusiasts.

<https://www.bernina.com/blog>

Available in English, German, Dutch and French.

BERNINA Social Media



Follow us on social networks to learn more about events, thrilling projects as well as tips and tricks about sewing, quilting and embroidering. We will keep you informed and we are looking forward to presenting highlights from the world of BERNINA.

<https://www.bernina.com/social-media>



1.4 Overview Machine

Overview Front Controls



- | | | | |
|---|------------------------|---|------------------------------|
| 1 | «Quick Reverse» | 6 | «Needle position Up/Down» |
| 2 | «Thread Cutter» | 7 | «Upper Multi-function Knob» |
| 3 | «Presser Foot Up/Down» | 8 | «Lower Multi-function Knob» |
| 4 | «Start/Stop» | 9 | «Needle Position Right/Left» |
| 5 | «Pattern End» | | |

Overview - Front



- | | | | |
|---|---|----|---------------------------------|
| 1 | Connection for Embroidery Module | 8 | Speed Control |
| 2 | Bobbin Cover | 9 | Thread Take-up Lever Cover |
| 3 | Connection for Accessory (Optional Accessory) | 10 | Thread Take-up Lever |
| 4 | Presser Foot | 11 | Thread Cutter |
| 5 | Needle Threader | 12 | Fixing Screw |
| 6 | Sewing Light | 13 | Connection for Slide-on Table |
| 7 | Thread Cutter | 14 | Connection for Free Hand System |

Overview - Side Panel



- | | | | |
|---|-----------------------------|----|-------------------------------------|
| 1 | Connection for Foot Control | 7 | Retractable Spool Pin |
| 2 | Feed Dog Up/Down | 8 | Air Vents |
| 3 | PC-Connection | 9 | Handwheel |
| 4 | USB Port | 10 | Power Switch |
| 5 | Spool Pin | 11 | Connection for Power Cable |
| 6 | Bobbin Winding Unit | 12 | Magnetic Holder for Touchscreen Pen |

Overview - Back Panel



- | | | | |
|---|-------------------------------|----|--------------------------|
| 1 | Air Vents | 9 | Bobbin Winding Unit |
| 2 | Connection for Slide-on Table | 10 | Bobbin Winder Pretension |
| 3 | Connection for Darning Hoop | 11 | Thread Take-up Lever |
| 4 | BERNINA Dual Feed | 12 | Thread Guide |
| 5 | Carrying Handle | 13 | Thread Cutter |
| 6 | Spool Pin | 14 | BSR Connection |
| 7 | Thread Guide Eye | 15 | Feed Dog |
| 8 | Retractable Spool Pin | 16 | Stitch Plate |

1.5 Supplied Accessories

Overview Accessories Machine

















Illustration	Name	Purpose
	Dust Cover	To protect the machine from dust and contamination.
	BERNINA Accessories Box	To store the supplied accessories as well as optional accessories.
	Free Hand System (FHS)	To raise and lower the presser foot.
	Slide-on Table	To increase the sewing surface.
	Seam Guide for Slide-On Table	To support wide topstitching of edges.
	Spool Cap	To support the regular unwinding of the thread from the spool.
	Bobbin for B9 Hook Set of 4	To wind the bobbin thread.
	Foam Pad 2 pieces	The foam pad prevents the thread from slipping, tangling or breaking on the spool pin.
	Touchscreen Pen	For precise operation of the touch screen.

Illustration	Name	Purpose
	Seam Ripper	To undo seams and to cut buttonholes open.
	Height Compensating Tool	To level an angled position of the presser foot sole when sliding over thick seams.
	Needle Assortment	For any common applications.
	Screwdriver red (slot)	To loosen and tighten slotted screws.
	Brush/Needle Inserter	To clean the feed dog and the looper area.
	Sewing Machine Oil	To oil the machine.
	Power Cable	To connect the machine with the power supply system.
	Foot Control	To start and stop the machine. To control the sewing speed.

Overview Presser Feet

Supplied Standard Presser Feet









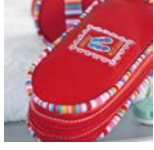



Illustration	Number	Name	Purpose	Example
	#1C	Reverse Pattern Foot	For sewing different practical and decorative stitches. To sew forward and in reverse.	

Illustration	Number	Name	Purpose	Example
	#1D	Reverse Pattern Foot	For sewing different practical and decorative stitches. To sew forward and in reverse.	
	#2A	Overlock Foot	To finish edges in stretch material.	
	#3A	Buttonhole Foot with Slide	To sew buttonholes automatically.	
	#4D	Zipper Foot	For sewing in zippers.	
	#20C	Open Embroidery Foot	For sewing applications and decorative patterns.	
	#97D	Patchwork Foot	For patchwork and other exact work, if working with BERNINA Dual Feed.	

Accessories Box



- | | | | |
|---|--------------|---|---|
| 1 | Drawer | 5 | Foam Pad |
| 2 | Presser Feet | 6 | Buttonhole Foot with Slide |
| 3 | Spool Pin | 7 | Needle Assortment |
| 4 | Spool Caps | 8 | Holder for 5.5 mm and 9.0 mm presser feet |

1.6 Overview User Interface

Overview Functions/Visual Information

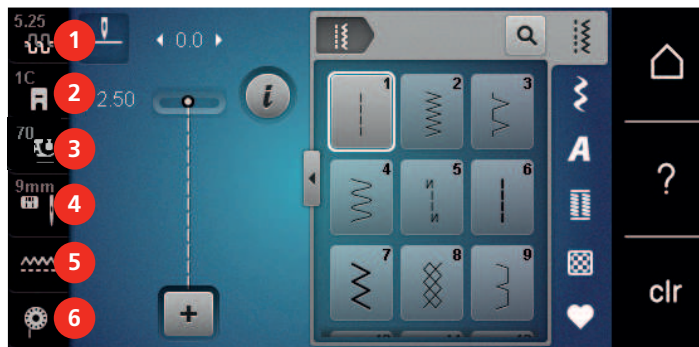

- | | | | |
|---|---|---|---------------------------------|
| 1 | «Upper Thread Tension» | 4 | «Stitch Plate/Needle Selection» |
| 2 | «Presser Foot Indicator/Presser Foot Selection» | 5 | «Feed Dog Indicator» |
| 3 | «Presser Foot Pressure» | 6 | «Bobbin Thread» |

Overview System Settings

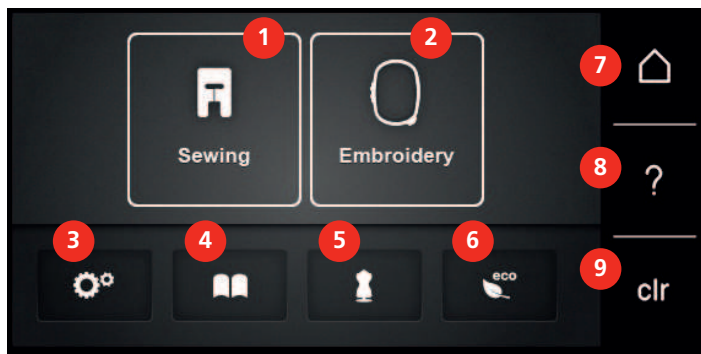

- | | | | |
|---|-----------------------|---|------------------|
| 1 | «Sewing Mode» | 6 | «eco Mode» |
| 2 | «Embroidery Mode» | 7 | «Home» |
| 3 | «Setup Program» | 8 | «Help» |
| 4 | «Tutorial» | 9 | «Clear Settings» |
| 5 | «Creative Consultant» | | |

Overview Selection Menu Sewing

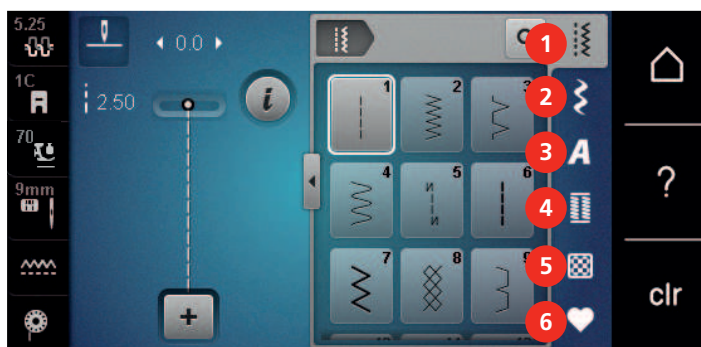

- | | | | |
|---|-----------------------|---|-------------------|
| 1 | «Practical Stitches» | 4 | «Buttonholes» |
| 2 | «Decorative Stitches» | 5 | «Quilt Stitches» |
| 3 | «Alphabets» | 6 | «Personal Memory» |

Software Operation

The touch-sensitive display can be operated with the finger or stylus.

Tap: Short tap of an element..

Swipe: Tap an element and swipe quickly on the display.

Draw: Tap the display and slowly move in one direction, eg. for scrolling up and down.

Navigation











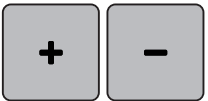

Illustration	Name	Purpose
	«Home»	Switch between «Home Screen» and «Sewing Screen».
	Navigation Path	Show a previous menu level.

Illustration	Name	Purpose
	«Close»	Close the window.
	More	Show more features or information.
	Continue	Scroll to next display.
	Back	Scroll to previous display.

Activate/Deactivate Functions

Illustration	Element	Status
	Switch	Function is activated.
		Function is deactivated.
	Icon	Function is deactivated.
		Function is activated.









Adjust Values

Illustration	Name	Purpose
	Slider Control	Set the value with the slider control. Reset the value to the default value by tapping the small bullet.
	Field «Plus» / «Minus»	«Plus» increase, «Minus» reduce the value.
	Yellow Frame	Indication that the set value differs from the default value. Reset the value to the default value by tapping.

Enter Text and Numbers

To enter numerical values or text, a corresponding keyboard is shown.



Illustration	Name	Purpose
	Entry Field	Display of the entry. Delete all characters entered with a single tap.
	«Deleting»	Delete the last character.
	«Lower Case Characters»	Show the available letters in lower case letters.
	«Upper Case Characters»	Show the available letters in upper case letters.
	«Numbers and Mathematical Characters»	Show the available numbers and mathematical characters.
	«Special Characters»	Show the available special characters.
	«Confirm»	Confirm the entry and leave the submenu.
	«Cancel»	Cancel the entry and the view closes.

1.7 Needle, Thread, Fabric

Needles will wear down over time. Therefore, the needle should be replaced regularly. Only a perfect point results in a good stitching result. In general, the thinner the fabric, the finer the needle. The illustrated needles are either standard or optional accessory, depending on the machine.

- Needle sizes 70, 75: for light-weight fabrics.
- Needle sizes 80, 90: for medium fabrics.
- Needle sizes 100, 110 and 120: for heavy fabrics.

Overview Needles

Illustration	Needle Name	Needle Description	Purpose
	Universal Needle 130/705 H 60/8 – 120/19	With a slightly rounded point.	For woven fabrics (light, medium, heavy-weight), knitwear, leather, plastic, jeans/denim. For natural and synthetic fabrics. For general sewing, sewing on buttons and buttonholes, zippers, hems and topstitching, decorative sewing, embroidery, patchwork, quilting.
	Stretch Needle 130/705 H-S 75/11 – 90/14	With a medium ball point.	For knitwear (jersey, tricot, knit and stretch material). For general sewing, sewing on buttons and buttonholes, zippers, hems and topstitching, decorative sewing, embroidery.
	Jersey/Embroidery Needle 130/705 H SUK 80/12	With a medium ball point.	For woven fabrics (light, medium, heavy-weight), knitwear, plastic. For general sewing, sewing on buttons and buttonholes, zippers, hems and topstitching, decorative sewing, embroidery.
	Jeans Needle 130/705 H-J 80/12 – 110/18	With slim, particularly acute point.	Woven fabrics (light, medium, heavy-weight), leather, jeans/denim. For general sewing, sewing on buttons and buttonholes, zippers, hems and topstitching, decorative sewing, embroidery, patchwork, quilting.
	Leather Needle Leather Needle 90/14, 100/16	With a cutting point (LR = special point to sew leather).	For leather, imitation leather and other similar materials. For zippers, hems and topstitching, materials that tend to stick.
	Microtex Needle 130/705 H-M 60/8 – 110/18	With a particularly pointed and slender tip.	For woven fabrics (light, medium, heavy), artificial materials and materials that are difficult to work with. For silk, microfibre fabrics, foils, coated and hard-sliding materials. For sewing in general, sewing on buttons and buttonholes, zips, hems and topstitching and decorative sewing. For ultra straight stitches when topstitching edges.

Illustration	Needle Name	Needle Description	Purpose
	Quilting Needle 130/705 H-Q 75/11 – 90/14	With a very slim, slightly rounded point.	For woven fabrics (light, medium and heavy-weight). Decorative sewing, patchwork, quilting. For stitching/topstitching tasks, such as quilting and patchwork.
	Embroidery Needle 130/705 H-E 75/11 – 90/14	With a light ball point and a particularly wide eye and wide groove.	For woven fabrics (light, medium, heavy-weight), knitwear. For voluminous and woolen threads. For general sewing, sewing on buttons and buttonholes, zippers, hems and topstitching, decorative sewing, embroidery.
	Fine Fabrics Needle 130/705 H SES 70/10 – 90/14	With a light ball point.	For fine, delicate materials, such as velvet. For general sewing, sewing on buttons and buttonholes, zippers, hems and topstitching, decorative sewing, embroidery, patchwork, quilting.
	Metafil Needle 130/705 H METAFIL 80/12	With medium ball point and long eye (2 mm).	For woven fabrics (light, medium, heavy-weight), knitwear. For sewing with special effects and fancy threads, especially metallic threads. For embroidery with metallic thread. For hems and topstitching, decorative sewing and embroidery.
	Topstitch Needle 130/705 H-N 80/12 – 100/16	With medium ball point and long eye (2 mm).	For woven fabrics (light, medium and heavy-weight). For hems and topstitching, decorative sewing and embroidery. For decorative and quilting work with several sewing threads and also for embroidery.
	Felting Needle PUNCH	With small barbs.	For woven fabrics (light, medium, heavy-weight), jeans/denim. For felting a variety of yarns and threads into base fabrics.
	Hemstitch Needle 130/705 H WING 100/16, 120/20	With a «wing» on each side of the needle blade.	For woven fabrics (light, medium and heavy-weight). For special effects with hemstitch embroidery.

Illustration	Needle Name	Needle Description	Purpose
	Universal Twin Needle 130/705 H ZWI 70-100	Needle distance: 1.0/1.6/2.0/2.5/3.0/4.0/6.0/8.0	For visible hems in stretch fabrics, pintucks, decorative sewing.
	Stretch Twin Needle 130/705 H-S ZWI 75	Needle distance: 2.5/4.0	For visible hems in stretch fabrics, pintucks, decorative sewing.
	Hemstitch Twin Needle 130/705 H ZWIHO 100	Needle distance: 2.5	For special effects with hemstitch embroidery.
	Universal Triple Needle 130/705 H DRI 80	Needle distance: 3.0	For visible hems in stretch fabrics, decorative sewing.

Example for Needle Description

The 130/705 system, which is the most common for household machines, is explained by the following picture of a Jersey/Stretch needle.

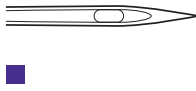
	<p>130/705 H-S/70</p> <p>130 = Shank length (1)</p> <p>705 = Flat shank (2)</p> <p>H = Needle scarf (3)</p> <p>S = Needle point (here medium ball point) (4)</p> <p>70 = Needle size 0.7 mm (5)</p>
---	---

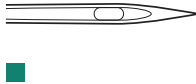
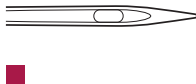
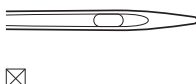
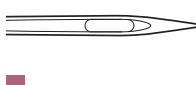
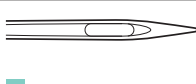
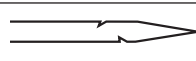
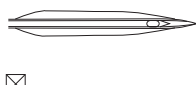
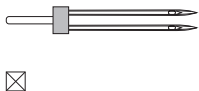
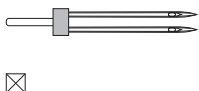
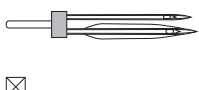
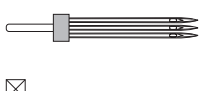
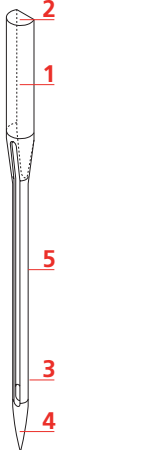
Thread Selection

For a perfect sewing result, thread and fabric quality play an important role.

We recommend purchasing quality threads to achieve good sewing results.

- Cotton threads have the advantage of being a natural fiber and therefore are especially suitable for sewing cotton fabrics.
- Mercerized cotton threads have a slight sheen that is not lost with washing.
- Polyester threads have a high tensile strength and is particularly colorfast.
- Polyester threads are more flexible and are recommended where a strong and elastic seam is required.



- Rayon threads are made of natural fibers and have a brilliant sheen.
- Rayon threads are suitable for decorative stitches and achieve a more beautiful effect.

Needle/Thread Combination

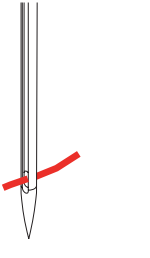
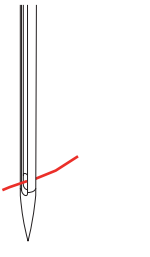
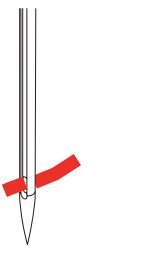
	<p>The needle/thread combination is correct, when the thread fits perfectly into the long groove and goes easily through the needle eye. The thread can be optimally sewn.</p>
	<p>The thread can break and skipped stitches can occur when there is too much clearance in the long groove and the needle eye.</p>
	<p>The thread can break and get stuck when the thread scrapes against the edge of the long groove not fit well into the needle eye optimally.</p>

2 Sewing Preparation

2.1 Before Using the Machine for the First Time



BERNINA recommends lubricating the hook before using the machine for the first time or after a longer period of non-use. (see page 150)

By oiling the hook, the occurrence of unwanted noises in the hook area can be avoided.

2.2 Accessories Box

Removing and Mounting the Accessory Box from Machine

The accessory box is fixed to the machine by means of four magnets. When attaching, the drawer has to be integrated in the accessory box.

- > Turn the carrying handle up and hold it in place.
- > Tilt the accessory box slightly forward and pull it off.



- > Close the doors of the accessory box.
- > Attach the accessory box to the machine, having the back towards the machine.

Storing Accessory



- > Insert the holders (1) for bobbins, feet and needles.
- > Store small parts in the drawer_(2), e.g. oiler.

NOTICE

Scratched Sensor Surfaces of the Bobbin

Malfunction of the lower thread indicator. If the sensor surfaces of the bobbins are scratched or dirty, the bobbin thread indicator will no longer detect the low thread level.

- > Always position the bobbins in the bobbin holder with the silver sensor surface to the right.
- > Insert the bobbins into the compartment (3) of the accessory box so that the silvery sensor surfaces are on the right side.
- > To remove a bobbin, press the compartment holder down.
- > Place the small and the medium spool caps on the pin (4).
- > Store foam pads in the compartment (5).
- > Store the Buttonhole Foot with Slide #3A in compartment (6).
- > Store the provided needle assortment in the special compartment (7).
- > Store the presser feet in the holders (1) (5.5 mm or 9.0 mm).

2.3 Connection and Switching On

Connecting the Foot Control

The cable of the foot control is rolled up on its underside.

- > Unroll the cable of the foot control to the desired length and fix it in the cable holders of the foot control.



- > Insert the plug of the cable into the foot control socket of the machine.



- > Place the foot control under the table.
- > If the cable is too long, roll up the excess length and fix it in the cable holders of the foot control.

Connecting the Machine

To ensure safe operation of the machine, only the supplied mains cable may be used. The supplied power cable is designed for the voltage range applicable in the country of use. If the machine is to be used in a country other than the country of origin, the power cable suitable for that country must be obtained from the Authorized BERNINA dealer.

The power cable for the USA and Canada has a polarized power plug (one contact is wider than the other). To reduce the risk of an electric shock, the plug can only be inserted into the socket in one way. If the power plug does not fit in the socket, reverse then insert the power plug. If the reversed power plug still does not fit, an electrician must install an appropriate socket. Do not modify the power plug in any way.

- > Insert the device connector of the power cable into the machine's power cable connection.



- > Insert the power plug of the power cable into the socket.

Attaching the Knee Lifter of the Free Hand System



The lateral position of the lever can be adjusted by your local BERNINA Dealer required.

- > Insert the knee lifter into the opening at the front side of the machine.
- > Adjust the sitting height so that the knee lifter can be operated with the knee.



Fixing the Touch Screen Pen

- > Store the touchscreen pen at the magnet holder.



Switching the Machine On

- > Set the power switch to «I».



2.4 Foot Control

Regulating the Speed via the Foot Control

Via the foot control the speed can be adjusted infinitely variable.

- > Press the foot control down carefully to start the machine.
- > To sew faster, press the foot control harder.
- > Release the foot control to stop the machine.



Activate/Deactivate Additional Function

The Foot Control can be programmed with a second function that can be activated and deactivated by a Back-kick. On delivery, the Back-kick is programmed with the function «Needle Up/Down».

> To raise or lower the needle, press the foot control downward with your heel.



The Back-kick function can be programmed individually. (see page 50)

2.5 Spool Pin

Retractable Spool Pin

Raise the Retractable Spool Pin



With metallic or other special threads, it is recommend to use the retractable spool pin.

The retractable spool pin is required when sewing with multiple threads, and can be used for spooling while sewing.

> To raise the spool pin, push the spool pin down and release it.



- > To lock the spool pin, turn the spool pin anti-clockwise as far as it will go.
- > To release the lock, turn the spool pin clockwise as far as it will go.
- > To lower the spool pin, push the spool pin down until it clicks into place.

Inserting Foam Pad and Thread Spool

The foam pad prevents the thread from getting hooked at the spool pin.

> Place the foam pad on the spool pin.

- > Place the thread spool on the spool pin.



Horizontal Spool Pin

Placing the Foam Pad, the Thread Spool and the Spool Cap

Spool caps hold the thread spool in place for proper release of thread from the spool. The spool cap is only used with the horizontal spool holder.

- > Place the foam pad on the spool pin.
- > Place the thread spool on the spool pin.
- > Position the appropriate spool cap on the spool pin so that there is no space between the spool cap and the thread spool.



Using the Spool Net

The spool net holds the thread on the thread spool and prevents the thread from knotting and breaking.

- > If available, slide the spool net over the thread spool. Ensure when doing so that the spool net does not slip off the thread spool, e.g. double-insert the net over the thread spools or insert a part of the net into the thread spool at the rear.



2.6 Feed Dog

Adjusting the Feed Dog

- > To lower the feed dog, push the button «Feed Dog Up/Down».



- > To raise the feed dog, push the button «Feed Dog Up/Down» again.

2.7 Slide-on Table

Using the Slide-on Table

The Slide-on Freearm Extension Table, attached to the freearm, enables the available sewing area to be extended.

- > Raise the needle.
- > Raise the presser foot.
- > Switch off the machine.
- > Push the Slide-on Freearm Extension Table from the left to the right over the freearm until it engages.



- > To remove the Slide-on Freearm Extension Table, press the button at the table down and pull the slide-on table over the free arm to the left.



Using the Seam Guide

The seam guide for the slide-on table facilitates sewing of evenly wide edges and hems.

Prerequisite:

- The slide-on table has been fitted.
- > Touch the release button and engage the seam guide from the front to the back on the slide-on table.



- > To determine the edge width, press the release button and move the seam guide to the right or left.
- > Touch the release button and pull the seam guide away to the front.



2.8 Presser Foot

Adjusting the Presser Foot Position via the Knee Lifter of the Free Hand System

- > Adjust the sitting height so that the knee lifter can be operated with the knee.
- > Push the knee lifter with the knee to the right to raise the presser foot.

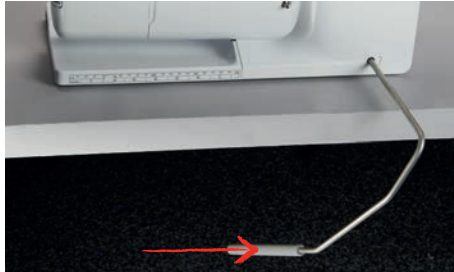

- Simultaneously the feed dog is lowered and the thread tension is released.
- > Release the knee lifter slowly to lower the presser foot.

Adjusting the Presser Foot Position via the Button «Presser Foot Up/Down»



- > To raise the presser foot, push the button «Presser Foot Up/Down».
- > To lower the presser foot, push the button «Presser Foot Up/Down» again.

Changing the Presser Foot

- > Raise the needle.
- > Raise the presser foot.
- > Switch the machine off.
- > Push the clamping lever up (1).
- > Remove the presser foot (2).



- > Guide the new presser foot upwards over the cone.
- > Press the clamping lever down.

Selecting the Presser Foot in the User Interface

After changing the presser foot, a check can be performed to determine whether it is suitable for the selected stitch pattern. Additionally, alternative presser feet are displayed, which are available for the selected stitch pattern.

- > Switch the machine on.
- > Select the stitch pattern.
- > Tap «Presser Foot Indicator/Presser Foot Selection».





> To display all suitable presser feet for the selected stitch pattern, tap «Optional Presser Feet».



> Select the attached presser foot.

- When the selected presser foot is suitable, sewing can start.
- If the selected presser foot is not suitable for the selected stitch pattern, it can still be selected but the machine is automatically prevented from starting. An error message is displayed. If an incorrect presser foot is selected, the sewing stitch is displayed in red in the sewing stitch preview.



Setting the Presser Foot Pressure



The presser foot pressure is designed to adjust the pressure of the presser foot optimally to the fabric thickness. When working with thick fabrics, it is recommended to reduce the presser foot pressure. This provides the advantage that the fabric can be moved more easily. When the presser foot pressure is set below 0, the presser foot even lifts to give more space to the thick fabric. When working with thin fabrics, it is recommended to increase the presser foot pressure. This provides the advantage that the fabric cannot be moved too easily under the presser foot.



- > Tap «Presser Foot Pressure».
- > Adjust the presser foot pressure.

2.9 Adjusting the Feed Dog



- > Tap «Feed Dog Indicator».
- > Raise or lower the feed dog according to the animation.

2.10 Needle and Stitch Plate

Changing the Needle

- > Switch the machine off.
- > Remove the presser foot.

- > Loosen the fixing screw for the needle by hand.



- > Pull the needle down.
- > Hold the new needle with the flat side to the back.
- > Insert the needle as far as it will go.
- > Tighten the fixing screw by hand.

Selecting the Needle in the User Interface

After changing the needle, you can check whether this can be used with the selected stitch plate.



- > Tap «Stitch Plate/Needle Selection».
- > Select the fitted needle.



- If the selected needle is suitable in combination with the selected presser foot, sewing can be started. If the selected needle does not correspond with the selected presser foot, there will be an error message when switching on the machine, and the machine will not start.

Selecting the Needle Type and the Needle Size

Useful reminder function: So that no information is lost, the needle type and needle thickness can also be saved on the machine. This means that the saved needle type and needle thickness can be checked at any time.



- > Tap «Stitch Plate/Needle Selection».



- > Tap «Needle Selection».

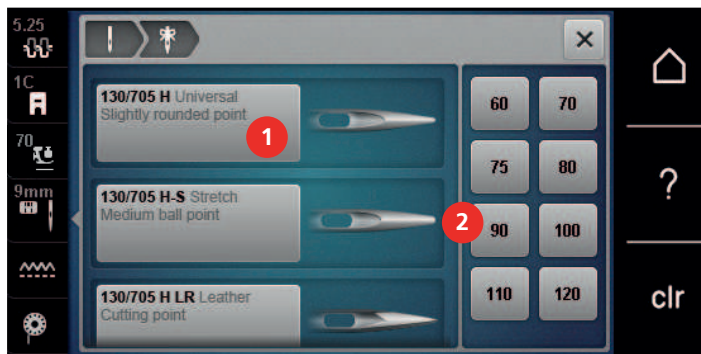

- > Select the needle type (1) of the fitted needle.
- > Select the needle type (2) of the fitted needle.

Adjusting the Needle Position Up/Down



- > To lower the needle, push the button «Needle position Up/Down».
- > To raise the needle, push the button «Needle position Up/Down» again.

Adjusting the Needle Position Left/Right

There is a total of 11 needle positions. The needle position is indicated by the needle position number in the display.

- > To position the needle position to the left, push the button «Needle Position Left» (1).
- > To position the needle position to the right, push the button «Needle Position Right» (2).



Needle Stop Up/Down (Permanent)



- > To set the needle stop position permanently, tap «Needle Stop Up/Down».
 - The machine stops with needle position down as soon as the foot control is released or the button «Start/Stop» has been pushed.
- > Tap «Needle Stop Up/Down» again.
 - The machine stops with needle position up as soon as the foot control is released or the button «Start/Stop» has been pushed.

Changing the Stitch Plate

The stitch plate is marked with vertical, horizontal and diagonal lines in millimeters (mm) and inches (inch). These markings are helpful for sewing or precise top-stitching.

Prerequisite:

- The feed dog is lowered.
- The machine is switched off.
- The needle and presser foot are removed.

- > At the marking on the upper right corner of the stitch plate, push the stitch plate downwards until it tips.



- > Remove the stitch plate.
- > Place the openings of the new stitch plate above the corresponding guide pins and press down until it clicks into place.

Selecting the Stitch Plate in the User Interface

After changing the stitch plate, you can check whether it can be used with the selected needle.



- > Tap «Stitch Plate/Needle Selection».
- > Select the previously fitted stitch plate.



- If the selected stitch plate is suitable to be used in combination with the needle, sewing can begin.
- If the selected stitch plate is not suitable to be used in combination with the needle, an error message is displayed and the machine is automatically prevented from starting.

2.11 Threading

Threading the Upper Thread

Preparing the Threading

- > Place the foam pad on the spool pin.
- > Place the thread spool on the spool pin so that the thread unwinds clockwise.
- > Attach the appropriate spool cap.
- > Switch on the machine and wait until it starts up.
- > Raise the needle and presser foot.

Guiding the Thread to the Needle

- > Hold the thread with one hand between the thread spool and rear thread guide (1). Use the other hand to hold the thread at the end and, during the subsequent steps, always keep it under light tension.
- > Guide the thread in direction of the arrow through the thread tension (2).



- > Guide the thread downwards around the thread take-up lever cover (3) and then upwards.
- > Insert the thread in the thread take-up lever (4).

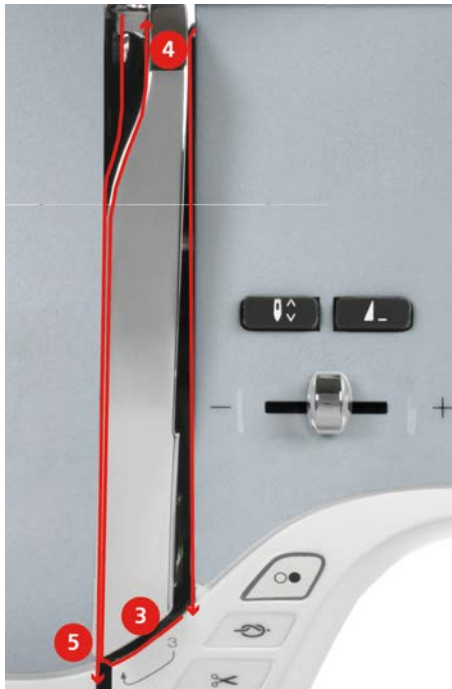

- > Guide the thread downwards again (5).
- > Only release the thread now.
- > Switch the machine off.

Threading the Needle

- > Guide the thread through the guides (6/7) above the presser foot.

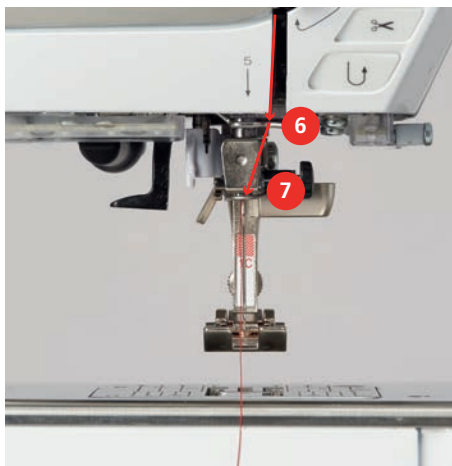

- > Pull the thread below the presser foot and through to the thread cutter (15), and cut it.

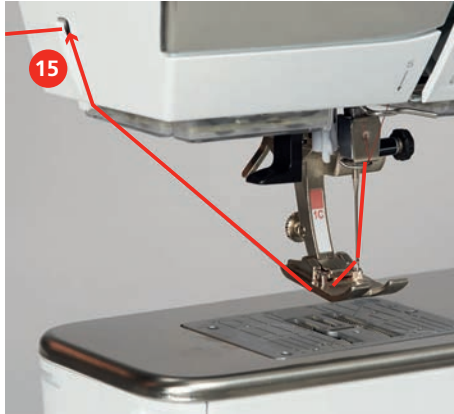

Threading the Twin Needle

Prerequisite:

- The twin needle is inserted.
- > Guide the first thread in direction of the arrow on the right side of the tension disc (1).
- > Guide the second thread in direction of the arrow on the left side of the tension disc (1).

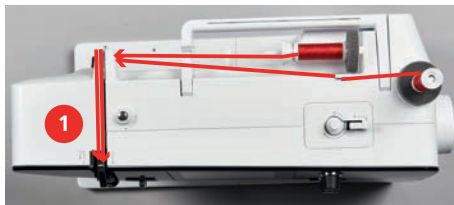

- > Guide the first and the second thread to the thread guide above the needle.
- > Thread the first thread manually into the right needle.
- > Thread the second thread manually into the left needle.

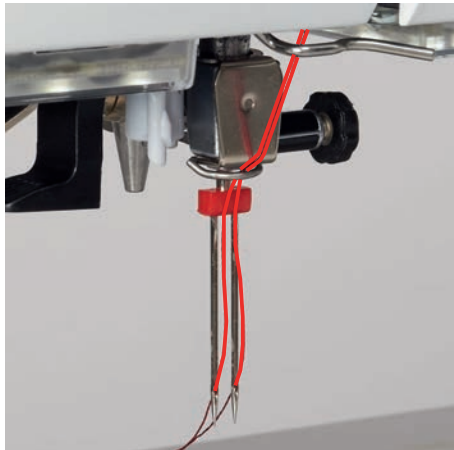

Threading the Triple Needle

Prerequisite:

- The triple needle is inserted.
- > Place the foam pad, the thread spool and the appropriate spool cap on the horizontal spool pin.
- > Place the foam pad on the vertical spool pin.
- > Fit the filled bobbin.
- > Attach the appropriate spool cap.
- > Attach the thread spool in the opposite direction to the bobbin.



- > Thread the 3 threads up to the upper thread guide.

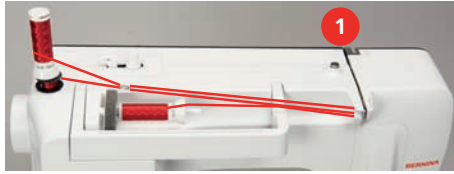

- > Guide 2 threads (vertical spool pin) past the thread tension disc (1) on the left and up to the thread guide above the needle.
- > Guide 1 thread (horizontal spool pin) past the thread tension disc (1) on the right and up to the thread guide above the needle.
- > Thread 1 thread of the vertical thread spool pin into the left and right needle by hand.
- > Thread the thread of the horizontal spool pin into the center needle manually.

Winding the Bobbin Thread



The bobbin thread can be wound while embroidering if the swiveling spool pin is used for winding.

Prerequisite:

- The foam pad, the thread spool and the appropriate spool cap are positioned.
- > Attach the empty bobbin on the winding unit so that the silvery sensor surface is down.



- > Guide the thread to the left into the rear thread guide (1).
- > Guide the thread around the bobbin winder pretension clockwise (2).
- > Wind the thread clockwise 2 – 3 times around the empty bobbin (3).
- > Pull the thread over the thread cutter at the engaging lever (4) and cut.

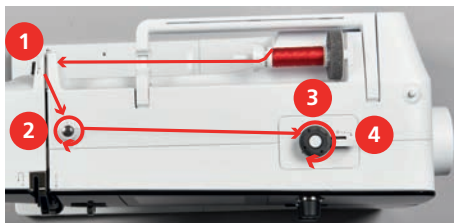

- > Push the engaging lever (5) towards the bobbin.



- The machine winds and the display to wind the bobbin appears.
- > Adjust the winding speed.

- > To stop the winding process, the engaging lever must be pushed to the right.
- > Push the engaging lever towards the bobbin again to continue the winding process.
 - As soon as the bobbin is full, the machine stops the winding process automatically.
- > Remove the bobbin and cut the thread using the thread cutter at the engaging lever.

Threading the Bobbin Thread

Prerequisite:

- The needle is raised.
- The machine is switched off and the bobbin cover is opened.
- > Press the bobbin case release at the bobbin case (1).

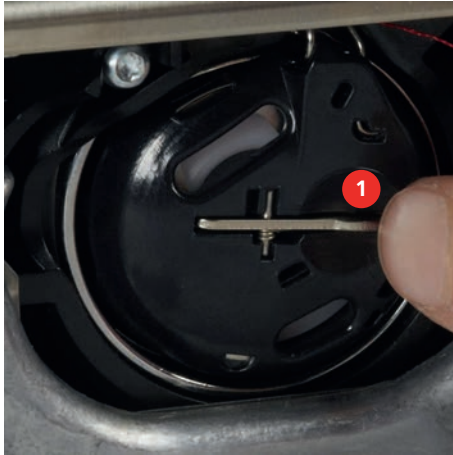

- > Remove the bobbin case.
- > Remove the bobbin from the bobbin case.
- > Insert the new bobbin so that the silvery sensor surface is facing the back of the bobbin case.



- > Pull the thread into the slot (2) from the left.



- > Pull the thread to the right under the spring (3), then pass it below the two thread guides (4) and pull it upwards.



- > To insert the bobbin case into the machine, hold it so that the thread guide (5) points upwards.



- > Insert the bobbin case.
- > Press onto the center of the bobbin case until it engages.



- > Pull the thread through the thread cutter (6) and cut.

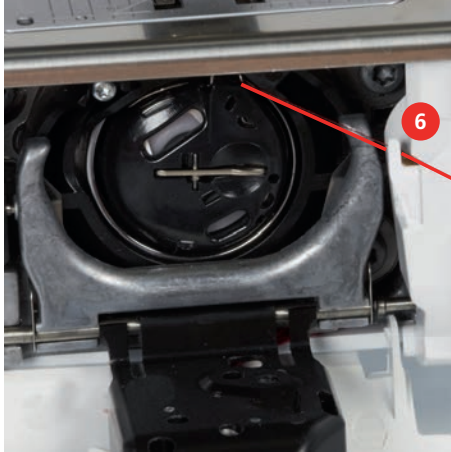

- > Close the looper cover.

Indicating Fill Level of Bobbin Thread

When the fill level of the bobbin thread is low, an animation appears in the icon «Bobbin Thread» to indicate that the bobbin thread is about to run out.



- > To thread the bobbin thread according to the animation, tap, «Bobbin Thread».

3 Setup Program

3.1 Sewing Settings

Adjusting the Upper Thread Tension

Changes to the upper thread tension in the Setup Program affect all of the stitch patterns. The setting in the setup is retained after the machine is switched off.



> Tap «Home».



> Tap «Setup Program».



> Tap «Sewing Settings».



> Tap «Adjusting the Upper Thread Tension».
> Adjust the upper thread tension.

Adjusting the Maximum Sewing Speed

You can use this function to set the maximum speed.



> Tap «Home».



> Tap «Setup Program».



> Tap «Sewing Settings».



> Tap «Maximum Sewing Speed».
> Set the maximum sewing speed.

Setting Securing Stitches (Smart Secure)

If the function is switched on, 4 securing stitches are automatically sewn at the start of the pattern after the thread cut.



> Tap «Home».



> Tap «Setup Program».



> Tap «Sewing Settings».



> Switch «Securing Stitches at the Start of the Pattern» on or off.





Adjusting the Hovering Height of the Presser Foot

The hovering height of the presser foot can be adjusted according to the fabric thickness from 0 to maximal 7 mm.

Set hovering height = fabric thickness + required clearance between the fabric and the presser foot in the floating position.













> Tap «Home».

-  > Tap «Setup Program».
-  > Tap «Sewing Settings».
-  > Tap «Programming Buttons and Icons».
-  > Tap «Programming the Hovering Height of the Presser Foot».
- > Adjust the distance between the fabric and the presser foot.





Programming the Button «Pattern End»

The presser foot can be positioned, the thread cut and the automatic securing can be programmed.

-  > Tap «Home».
-  > Tap «Setup Program».
-  > Tap «Sewing Settings».
-  > Tap «Programming Buttons and Icons».
-  > Tap «Programming the Button Pattern End».
-  > To activate the automatic securing, tap «Securing Stitches».
- > To deactivate the automatic securing, tap «Securing Stitches» again.
-  > To program subsequent securing stitches, tap «Securing Stitches in Close Succession».
- > To program the number of subsequent securing stitches, tap «Plus» or «Minus».
-  > To program 4 securing stitches in place, tap «Securing Stitches in Place».
-  > To deactivate the automatic thread cut after securing, tap «Automatic Thread Cutter».
- > To activate the automatic thread cut after securing, tap «Automatic Thread Cutter» again.
-  > To keep the presser foot in lowered position, tap «Raise the Presser Foot».
- > To raise the presser foot after securing, tap «Raise the Presser Foot» again.

Programming the Button «Thread Cutter»

The automatic securing can be programmed before the thread cut takes place.

-  > Tap «Home».
-  > Tap «Setup Program».
-  > Tap «Sewing Settings».
-  > Tap «Programming Buttons and Icons».
-  > Tap «Programming the Button Thread Cutter».



- > To activate the automatic securing, tap «Securing Stitches».
- > To deactivate automatic securing, tap «Securing Stitches» again.



- > To program subsequent securing stitches, tap «Securing Stitches in Close Succession».
- > To program the number of securing stitches, tap «Minus» or «Plus».



- > To program 4 securing stitches in place, tap «Securing Stitches in Place».

Adjusting the Presser Foot Position with Needle Stop Down

With the needle lowered, 3 different presser foot positions can be selected: Presser foot lowered, presser foot raised to hovering position and presser foot raised to maximum height.



- > Tap «Home».



- > Tap «Setup Program».



- > Tap «Sewing Settings».



- > Tap «Programming Buttons and Icons».



- > Tap «Pressure Foot Position with Needle Stop Down».



- > Select the desired presser foot position.

Programming the Button «Quick Reverse»

It can be either chosen «Reverse Sewing» or «Backstepping».



- > Tap «Home».



- > Tap «Setup Program».



- > Tap «Sewing Settings».



- > Tap «Programming Buttons and Icons».



- > Tap «Programming the Button Quick Reverse».



- > To set the stitch-precise reverse sewing, tap «Back Stepping».













- > To set the reverse sewing, tap «Quick Reverse».

Programming the Foot Control

If «Needle Up/Down» is activated, the needle is raised or lowered with the back-kick on the foot control. Alternatively, the presser foot can be positioned, the thread can be cut and the automatic securing can be programmed.







- > Tap «Home».

-  > Tap «Setup Program».
-  > Tap «Sewing Settings».
-  > Tap «Programming the Foot Control».
- 
 - «Needle Up/Down» is activated in the default setting.
 - The back-kick on the foot control raises or lowers the needle.
-  > To program the Back-kick, tap «Programming the Back-kick».
- 
 - > To deactivate the automatic securing via the Back-kick, tap «Securing Stitches».
 - > To activate the automatic securing via the Back-kick, tap «Securing Stitches» again.
- 
 - > To program subsequent securing stitches, tap «Securing Stitches in Close Succession».
 - > To program the number of securing stitches, tap «Minus» or «Plus».
-  > To program 4 securing stitches in place, tap «Securing Stitches in Place».
- 
 - > To deactivate the automatic thread cut via the Back-kick, tap «Automatic Thread Cutter».
 - > To activate the automatic thread cut via the Back-kick, tap «Automatic Thread Cutter» again.
- 
 - > To keep the lowered position of the presser foot via the Back-kick, tap «Raise the Presser Foot».
 - > To keep the raised position of the presser foot via the Back-kick, tap «Raise the Presser Foot» again.

3.2 Embroidery Settings





Adjusting the Upper Thread Tension

Changes to the upper thread tension in the Setup Program affect all of the embroidery designs. The setting in the Setup Program is retained after the machine is switched off.

-  > Tap «Home».
-  > Tap «Setup Program».
-  > Tap «Embroidery Settings».
- 
 - > Tap «Adjusting the Upper Thread Tension».
 - > Adjust the upper thread tension.

Adjusting the Maximum Embroidering Speed

The maximum speed can be reduced by this function.

-  > Tap «Home».
-  > Tap «Setup Program».
-  > Tap «Embroidery Settings».
- 
 - > Tap «Maximum Embroidering Speed».
 - > Set the maximum sewing speed.

Setting the Embroidery Design Position when Opening

As the default setting, opened embroidery designs are always displayed in the center of the hoop. You can use the switch «Restore saved embroidery design position» to set that embroidery designs are opened at the position in the hoop at which they had been saved in the BERNINA Embroidery Software.



> Tap «Home».



> Tap «Setup Program».



> Tap «Embroidery Settings».



> Tap «Centering the Embroidery Design».



> To open the embroidery design at the saved position, set the switch «Restore saved embroidery design position» to «I».

> To open the embroidery design in the center of the hoop, set the switch «Restore saved embroidery design position» to «0».

Calibrating the Embroidery Hoop

The calibration of the embroidery hoop is the coordination of the needle to the center of the embroidery hoop.

Prerequisite:

- The embroidery module is connected.
- The hoop is fitted with the corresponding embroidery pattern.



> Tap «Home».



> Tap «Setup Program».



> Tap «Embroidery Settings».



> Tap «Calibrating the Embroidery Hoop».





> Use the arrow icons on the display to move the needle precisely to the center of the pattern.



> To save the calibration, tap «Confirm».





Entering the Fabric Thickness

If the fabric thickness is more than 4 mm, e. g. such as terry cloth, then it is recommended to choose 7.5 mm or 10 mm. The thicker the fabric, the slower the machine embroiders. When the machine is switched off, the changes are reset to the default setting of 4 mm.

-  > Tap «Home».
-  > Tap «Setup Program».
-  > Tap «Embroidery Settings».
-  > Tap «Entering the Fabric Thickness».
- > Select fabric thickness.









Activating/Deactivating the Function Thread Away

To pull the thread end out of the fabric being cut, the function must be activated. For embroidery designs with long stitches, it is recommended to deactivate the function thread away. When the distance between the presser foot and the embroidery hoop is too short, the function is not carried out.

-  > Tap «Home».
-  > Tap «Setup Program».
-  > Tap «Embroidery Settings».
-  > Tap «Thread Away».
-  > Activating/Deactivating the function Thread Away.

Programming Securing Stitches (Smart Secure)

Embroidery designs are programmed with or without securing stitches. If the embroidery design has programmed securing stitches, they will be embroidered. If embroidery designs are programmed with securing stitches, the securing stitches can be removed using the BERNINA Embroidery Software.

-  > Tap «Home».
-  > Tap «Setup Program».
-  > Tap «Embroidery Settings».
-  > Tap «Securing Stitches».
-  > To deactivate the securing stitches at the start, switch off the switch in the upper section.
 - If the embroidery design doesn't have any programmed securing stitches, none are embroidered.
-  > Turn on the switch in the upper section to deactivate the securing stitches at the start.
 - If the embroidery design doesn't have any programmed securing stitches, the securing stitches are added and will be embroidered.
-  > Turn off the switch in the lower section to deactivate the securing stitches at the end.
 - If the embroidery design doesn't have any programmed securing stitches, none are embroidered.
-  > Turn on the switch in the lower section to activate the securing stitches at the end.
 - If the embroidery design doesn't have any programmed securing stitches, the securing stitches are added and will be embroidered.

Adjusting the Thread Cut

The settings for the thread cut can be customized. Deactivate the thread cut before a color change (1) or adjust the length of the connecting stitch (3). The machine does the cutting of the connecting threads at the determined length for you. First, set the length from which the connecting stitches are cut, and then select the embroidery design.



The length of the connecting thread can be adjusted between 1 mm and 15 mm, the default setting is 6 mm. This means that all connecting stitches longer than 6 mm are cut automatically. If the value is reduced to 1 mm, more thread cuts are carried out, it takes longer to embroider and more loose thread ends can be seen on the wrong side of the fabric, especially when the function 'Thread-away' is activated too. On the right side of the fabric there will be practically none or merely very short connecting stitches which results in a wonderful stitch formation. Reducing the length of the thread cut to 1 mm is particularly of advantage when embroidering texts where usually many short connecting threads occur. When both sides of the embroidery designs are visible, it may be reasonable to not reduce the length of the thread cut so much so that there won't be too many loose thread ends on the wrong side of the fabric. Loose ends get sewn over and can hardly be removed afterwards.



> Tap «Home».



> Tap «Setup Program».



> Tap «Embroidery Settings».



> Tap «Thread Cut Settings».

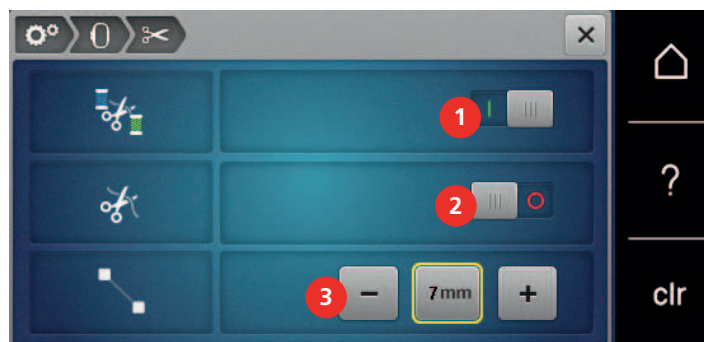

- > To deactivate the automatic thread cut before changing a thread, tap the switch in the upper section of the display (1).
- > To activate the automatic thread cut before changing a thread, tap the switch in the upper section of the display (1) again.
- > Tap the switch in the middle section of the display (2) so that the machine will stop after about 7 stitches and the remaining thread can be cut manually.
- > Tap the switch in the middle section of the display (2) again and the machine won't stop for a manual thread cut.
- > To adjust the length from where the connecting stitches are cut, tap «Minus» or «Plus» (3).

Changing the Measuring Unit

The unit of measurement in the embroidery mode can be changed from mm to inches. The default setting is mm.



> Tap «Home».



> Tap «Setup Program».



- > Tap «Embroidery Settings».



- > Tap «Measuring Unit».
- > To display the measurements in the Embroidery Mode in inch, tap «inch».
- > To display the measurements in the Embroidery Mode in mm, tap «mm».

3.3 Selecting Personal Settings



- > Tap «Home».



- > Tap «Setup Program».



- > Tap «Personal Settings».
- > Select the required display color and background.
- > Tap the text box above the color settings.
- > Enter and confirm the welcome text.

3.4 Monitoring Functions

Activating the Upper Thread Indicator



- > Tap «Home».



- > Tap «Setup Program».



- > Tap «Monitoring Functions».



- > Tap the switch in the upper section of the display to deactivate the upper thread indicator.
- > Tap the switch again to activate the upper thread indicator.

Activating the Bobbin Thread Indicator



- > Tap «Home».



- > Tap «Setup Program».











- > Tap «Monitoring Functions».



- > Tap the switch in the lower section of the display to deactivate the bobbin thread indicator.
- > Tap the switch again to activate the bobbin thread indicator.





3.5 Activating the Audio Signals



-  > Tap «Home».
-  > Tap «Setup Program».
-  > Tap «Setting Sound».
-  > To switch all audio signals on or off, tap (1).
-  > To switch off the sound when selecting a stitch pattern, tap the corresponding «Switching Sounds On/Off» in area (2).
-  > To switch on the sound when selecting a stitch pattern, tap the corresponding in area (2) «1 – 4».
-  > To switch off the sound for selecting functions, tap the corresponding «Switching Sounds On/Off» in area (3).
-  > To switch on the sound for selecting functions, tap the corresponding in area (3) «1 – 4».
-  > To deactivate the sound of the beeper when using the BSR Modes, tap «Switching Sounds On/Off» in the sector (4).



3.6 Machine Settings

Selecting a Language

-  > Tap «Home».
-  > Tap «Setup Program».
-  > Tap «Machine Settings».
-  > Tap «Language Selection».
-  > Tap the required language.

Adjusting the Brightness of the Display





The brightness of the display can be set to meet your individual needs.

-  > Tap «Home».
-  > Tap «Setup Program».
-  > Tap «Machine Settings».

- > Tap «Display Settings».
- > Adjust the brightness of the display in the upper section of the screen.





Adjusting the Sewing Light

The brightness of the sewing light can be adjusted corresponding to the personal preferences.

-  > Tap «Home».
-  > Tap «Setup Program».
-  > Tap «Machine Settings».
-  > Tap «Display Settings».
- > Adjust the brightness of the sewing light in the lower section of the screen.
-  > Tap the switch to switch the sewing light off.
- > Tap the switch again to switch the sewing light on.







Reviewing the Total Number of Stitches

The total number of stitches by the machine and the number of stitches since the last maintenance carried out by a specialist BERNINA dealer are displayed.

-  > Tap «Home».
-  > Tap «Setup Program».
-  > Tap «Machine Settings».
-  > Tap «Information».
-  > Tap «Firmware and hardware information».

Registering Details of the Dealer

The contact details for your specialized BERNINA dealer can be entered.

-  > Tap «Home».
-  > Tap «Setup Program».
-  > Tap «Machine Settings».
-  > Tap «Information».
-  > To enter the dealer data, tap «Dealer Data».
-  > To enter the company name of the specialist BERNINA dealer, tap «Name».
-  > To enter the address of the specialized BERNINA dealer, tap «Address».



> To enter the telephone number of the specialized BERNINA dealer, tap «Phone Number».



> To enter the website or e-mail address of the specialized BERNINA dealer, tap «E-mail address».

Saving Service Data

The service data regarding the current status of the machine can be saved on a USB stick and consequently provided to the specialized BERNINA dealer.

> Insert a USB stick which provides enough free capacity into the USB port of the machine.



> Tap «Home».



> Tap «Setup Program».



> Tap «Machine Settings».



> Tap «Information».



> Tap «Service Data».

> Tap «Export the Service Data».

– The icon «Export the Service Data» is outlined in white.

> If the white frame is no longer displayed, remove the USB stick.

Back to Basic Setting

CAUTION: Using this function will delete all individually made settings.



> Tap «Home».



> Tap «Setup Program».



> Tap «Machine Settings».



> Tap «Factory Setting».



> To restore all default settings for sewing, tap «Default Setting Sewing» and confirm.



> To restore all default settings for embroidering, tap «Default Setting Embroidering» and confirm.



> To restore all default settings, tap «Default Setting Machine», confirm and restart the machine.

Deleting User Data

Patterns which are not needed anymore can be deleted to create space for new designs.



> Tap «Home».





> Tap «Setup Program».



> Tap «Machine Settings».







> Tap «Factory Setting».

-  > To delete all data from the Personal Memory, tap «Delete Data from Own Storage Medium» and confirm.
-  > To delete all embroidery designs from the Personal Memory, tap «Delete Personal Embroidery Designs» and confirm.

Deleting Designs on the BERNINA USB Stick

When designs which won't be needed anymore are saved on the BERNINA USB Stick, the stick can be connected to the machine and the data can be deleted.







- > Insert the BERNINA USB stick into the USB port of the machine.
-  > Tap «Home».
-  > Tap «Setup Program».
-  > Tap «Machine Settings».
-  > Tap «Factory Setting».
-  > Tap «Deleting USB Stick» and confirm.

Calibrating the Buttonhole Foot #3A

The Buttonhole Foot with Slide #3A is calibrated to the machine and they should only be used both together.

Prerequisite:

- The Buttonhole Foot with Slide #3A is fitted.
- The needle is not threaded.



-  > Tap «Home».
-  > Tap «Setup Program».
-  > Tap «Machine Settings».
-  > Tap «Maintenance/update».
-  > Tap «Calibrating the Buttonhole Foot #3A».
-  > To start the calibration, push the button «Start/Stop».
 - When the calibration is complete, the result is shown in the display.

Packing the Embroidery Module

To pack the embroidery module into the original packaging without moving the embroidery arm manually, the embroidery arm needs to be brought to its packing position.

Prerequisite:

- The embroidery module is connected with the machine.

-  > Tap «Home».
-  > Tap «Setup Program».

Setup Program



> Tap «Machine Settings».



> Tap «Maintenance/update».



> Tap «Packing Position».

> Follow the instructions on the display.



4 System Settings

4.1 Calling Up the Tutorial

The Tutorial gives information and explanations, covering various aspects of sewing, embroidering, and the different stitches.



> Tap «Home».



> Tap «Tutorial».

> Select the desired topic in order to view information.

4.2 Calling Up the Creative Consultant

The Creative Consultant informs you about decision support for sewing projects. After entering the kind of fabric and the desired sewing project, suggestions concerning the suitable needle or the appropriate presser foot are displayed.



> Tap «Home».



> Tap «Creative Consultant».

> Select the fabric on which you want to sew.

> Select the sewing project.



> Tap «Confirm».

– The settings are adjusted.

4.3 Using eco Mode

If work is interrupted for an extended period, the machine can be put into energy-saving mode. The power save mode eco also serves as a child safety feature. Nothing can be selected in the display and the machine cannot be started.



> Tap «Home».



> To activate the power save mode, tap «eco Mode».

– The display goes to sleep. The power consumption is reduced and the sewing light is off.

> To deactivate the power save mode, tap «eco Mode» again.

4.4 Calling Up the Help

> Touch the window in the display where help is needed.



> To start the Help Mode, tap «Help» twice.

> Tap the icon in the display where help is needed.

4.5 Cancelling any Alterations with «clr»

Any alterations to designs can be reset to basic setting. Exceptions are saved designs which have been filed in the personal memory and monitoring functions.



> Tap «Clear Settings».

5 Creative Sewing

5.1 Overview Selection Menu Sewing

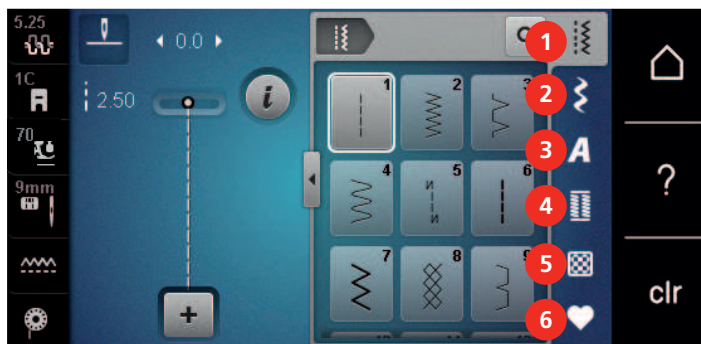

- | | | | |
|---|-----------------------|---|-------------------|
| 1 | «Practical Stitches» | 4 | «Buttonholes» |
| 2 | «Decorative Stitches» | 5 | «Quilt Stitches» |
| 3 | «Alphabets» | 6 | «Personal Memory» |

Selecting a Stitch Pattern

- > Select a stitch pattern, alphabet or buttonhole.
- > Wipe up in the area of the practical stitches, alphabets or buttonholes to have more stitch patterns displayed.
- > To increase the view, tap «Increasing/Decreasing the Display Size» (1).

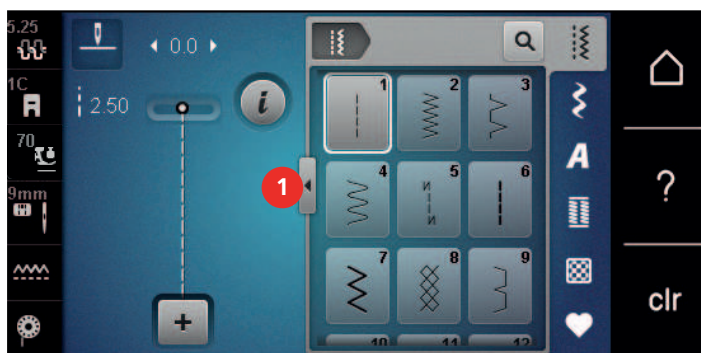

- > To decrease the view, tap «Increasing/Decreasing the Display Size» again.
- > To select the stitch pattern via the stitch number entry, tap «Select Stitch Pattern by Number».



5.2 BERNINA Dual Feed

The BERNINA Dual Feed feeds the fabric from above and from beneath simultaneously. This provides an even and careful feed forward even for smooth and thin materials. Striped and checkered patterns can be matched perfectly by even feeding.

In general, the BERNINA Dual Feed is used for the following sewing projects:

- Sewing: All sewing applications with difficult fabrics, e. g. seams, zippers.
- Patchwork: With accurate stripes, blocks and with decorative stitches up to a stitch width of 9 mm.
- Appliqués: Sewing on ribbons and bias binding.

Difficult-to-work-with fabrics are:

- Velvet, normally sewn with the grain.
- Toweling.
- Jersey, especially when sewing it crosswise to knit.
- Fake fur or coated fake fur.
- Fleece-types of fabrics.
- Batted fabrics.
- Stripes and checks.
- Curtain fabrics with pattern repeats.

«Sticky» fabrics are:

- Imitation leather, coated fabrics (optimally with optional accessory Zigzag Foot with Non-Stick Sole #52D).

5.3 Regulating the Speed

The sewing speed can be adjusted infinitely variable with the slide.

- > Move the slide to the left to reduce the sewing speed.
- > Move the slide to the right to increase the sewing speed.

5.4 Adjusting the Upper Thread Tension

The default setting of the upper thread tension is set automatically as soon as a stitch pattern or an embroidery design is selected.

The upper thread tension is set optimally at the BERNINA factory and the machine has been tested. Metrosene/Seralon thread size 100/2 (Mettler, Switzerland) is used for the upper and bobbin thread.

When using different types of sewing or embroidery threads, the upper thread tension may vary. Therefore it may be necessary to adjust the upper thread tension according to the sewing or embroidering project as well as the desired stitch pattern or the embroidery design individually.

The higher the upper thread tension is set, the tighter the upper thread is tensioned, and the bobbin thread is pulled deeper into the fabric. When the upper thread tension is low, the upper thread is less tightened, and the bobbin thread is pulled up less into the fabric.

Alterations of the upper thread tension affect the currently selected stitch pattern and all embroidery designs. Permanent alterations of the upper thread tension for the sewing mode (see page 51) and for the embroidering mode (see page 48) can be made in the Setup Program.

Prerequisite:

- The upper thread tension has been altered in the Setup Program.



- > Tap «Upper Thread Tension».
- > Adjust the upper thread tension.



- > Tap the yellow-outlined icon on the right side to reset the alterations to the default setting.
- > Tap the yellow-outlined icon on the left side to reset the alteration to default setting in the **Setup Program**.

5.5 Editing Stitch Patterns

Changing the Stitch Width

- > Turn the «Upper Multi-function Knob» to the left to narrow the stitch width.
- > Turn the «Upper Multi-function Knob» to the right to widen the stitch width.
- > To call up further setting options, tap the icon «Stitch width» (1).



Changing the Stitch Length

- > Turn the «Lower Multi-function Knob» to the left to shorten the stitch length.
- > Turn the «Lower Multi-function Knob» to the right to elongate the stitch length.
- > To call up other setting options, tap «Stitch Length» (1).

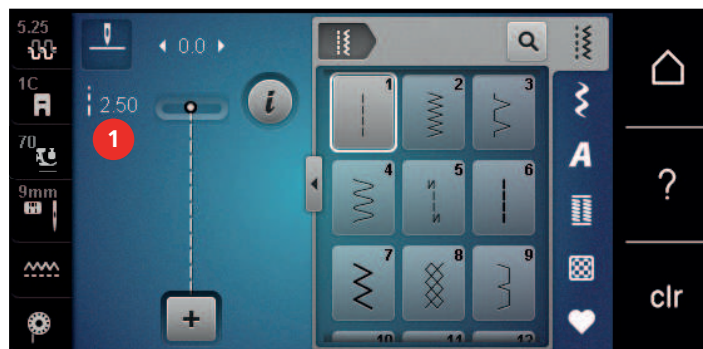

Correcting the Balance

Different fabrics, threads and stabilizers can affect the programmed stitch patterns so that they cannot be sewn out correctly. The electronic balance can correct these deviation and the stitch pattern can be adjusted optimally to the selected fabric.

- > Select a stitch pattern or alphabet.
- > Sewing stitch pattern.
- > Tap «i-Dialog».



- > Tap «Balance».
 - A preview of the stitch pattern is displayed.



- > To correct the longitudinal direction of the stitch pattern, turn the «Lower Multi-function Knob» until the preview of the stitch pattern matches the stitch pattern sewn on the fabric.
-  > Altered Balance settings can be saved for each stitch in the «Personal Memory» .
- > Altered Balance settings only remain valid until the «Clear Settings» is pushed or the machine is switched off.

Programming Pattern Repeat

Stitch patterns can be repeated up to 99 times.



- > Select a stitch pattern or alphabet.
- > Tap «i-Dialog».



- > Tap «Pattern Repeat».
- > Enter the required number of stitch patterns.



- > Tap «Confirm».



- > To deactivate the pattern repeat, tap and hold «Pattern Repeat».

Mirror Image of Stitch Patterns



- > Select a stitch pattern or alphabet.
- > Tap «i-Dialog».



- > To mirror the stitch pattern from left to right, tap «Mirror Image Left/Right».



- > To mirror the stitch pattern in sewing direction, tap «Mirror Image Up/Down».

Edit Stitch Pattern Length

The stitch patterns can be lengthwise extended or shortened.



- > Select a stitch pattern or alphabet.
- > Tap «i-Dialog».



- > Tap «Edit Stitch Pattern Length».
- > Adjust the stitch pattern length.

Programming the Stitch Counter Function

The Stitch Counter function cannot be set for all stitch patterns. If, for example, the Honeycomb Stitch No. 8 is selected, the stitch counter function cannot be used.



- > Select the stitch pattern.
- > Tap «i-Dialog».



- > Tap «Programming the Length via the Stitch Counter».
- > Sew the desired length.



- > Push the button «Quick Reverse».
 - The display changes to «Auto» and the selected stitch pattern in the new length is saved until the machine is switched off.



Sewing Stitch Patterns Using the Triple Stitch

The stitch pattern can be sewn three times for a more attractive result. Not all stitch patterns can be sewn using the triple stitch.

- > Select the stitch pattern.
- > Tap «i-Dialog».



- > Tap «Triple Stitch».

Quick Reverse

- > Select a stitch pattern or alphabet.
- > To switch immediately to sewing in reverse when pushing the button «Quick Reverse», select Needle Stop Down (permanent).
- > Program needle stop up (permanent) to sew another stitch forward before the machine switches to reverse sewing.



- > Push and hold the button «Quick Reverse».

Permanent Quick Reverse

- > Select a stitch pattern or alphabet.
- > Tap «i-Dialog».



- > To sew permanently in reverse, tap «Quick Reverse».
 - The machine sews permanently in reverse until «Quick Reverse» is tapped again.

Backstepping

- > Select a stitch pattern or alphabet.
- > Tap «i-Dialog».



- > To backstep the last 200 stitches, tap «Back Stepping».

5.6 Combining Stitch Patterns

Overview Combi Mode



- | | | | |
|---|-----------------|---|--|
| 1 | «Stitch Width» | 3 | «Combination Mode/Single Mode» |
| 2 | «Stitch Length» | 4 | Individual Stitch Pattern within the Combination |

Creating Stitch Pattern Combinations

In the Combi Mode stitch patterns and alphabets can be combined according to your wish. By combining any alphabet letters, the logo BERNINA can be created.

- + > Tap «Combination Mode/Single Mode».
- > Select the desired stitch patterns.



- + > To get back to the Single Mode, tap «Combination Mode/Single Mode» again.

Saving a Stitch Pattern Combination

To use an individually created stitch pattern combinations again, they can be saved in the folder «Personal Memory».

Prerequisite:

- A stitch pattern combination has been created.

- + > Tap «Personal Memory».
- + > Tap «Save Stitch Pattern».
- ✓ > To save the stitch pattern combination, tap «Confirm».

Loading a Stitch Pattern Combination

- + > Tap «Combination Mode/Single Mode».
- + > Tap «Personal Memory».
- + > Tap «Loading a Stitch Pattern Combination».
- > Select a stitch pattern combination.

Overwriting a Stitch Pattern Combination

Prerequisite:

- A stitch pattern combination has been created.

- + > Tap «Personal Memory».
- + > Tap «Save Stitch Pattern».
- > Select the stitch pattern combination which is to be overwritten.
- ✓ > To overwrite the stitch pattern combination, tap «Confirm».

Deleting a Stitch Pattern Combination

Prerequisite:

- A stitch pattern combination has been created.

-  > Tap «i-Dialog».
-  > Tap «Edit Entire Combination».
-  > Tap «Deleting».
-  > Tap «Confirm».

Editing a Single Stitch Pattern

Prerequisite:

- A stitch pattern combination has been created.
- > To select a single stitch pattern, tap the desired position (1) within the stitch pattern combination.



-  > To edit the single stitch pattern, tap «i-Dialog».

Deleting a Single Stitch Pattern

Prerequisite:

- A stitch pattern combination has been created.
- > Tap the desired stitch pattern (1) within the stitch pattern combination.



-  > Tap «i-Dialog».
-  > Tap «Deleting».

Adding a Single Stitch Pattern

The new stitch pattern is always inserted after the selected stitch pattern.

Prerequisite:

- A stitch pattern combination has been created.

> To select a single stitch pattern, tap the desired position (1) within the stitch pattern combination.



> Select a new stitch pattern.

Adapting the Stitch Pattern length and Stitch Pattern Width

The length and width of the individual stitch patterns in a stitch pattern combination can be adapted to the longest and widest stitch patterns in the combination.

Prerequisite:

- A stitch pattern combination has been created.



> Tap «i-Dialog».



> Tap «Edit Entire Combination».

> Tap «Total Pattern Length» (1).



> Tap «Adjust Length within the Combination» (2).

- The lengths of the stitch patterns are adapted to the length of the longest stitch pattern in the combination.

> Tap «Stitch Width» (3).



> Tap «Adjust Width within the Combination» (4).

- The widths of all of the stitch patterns are adapted to the width of the widest stitch pattern in the combination.

Furthermore, the length and width of the stitch pattern combination are increased or decreased proportionally.



- > To decrease the width of the stitch pattern combination proportionally, turn the «Upper Multi-function knob» to the left.
- > To increase the width of the stitch pattern combination proportionally, turn the «Upper Multi-function knob» to the right.
- > To decrease the length of the stitch pattern combination proportionally, turn the «Lower Multi-function knob» to the left.
- > To increase the length of the stitch pattern combination proportionally, turn the «Lower Multi-function knob» to the right.

Mirroring a Stitch Pattern Combination

Prerequisite:

- A stitch pattern combination has been created.



- > Tap «i-Dialog».



- > Tap «Edit Entire Combination».



- > To mirror the whole stitch pattern combination from left to right, tap, «Mirror Image Left/Right».
- > To reset the changes and revert to the default settings, tap «Mirror Image Left/Right».

Stitch Pattern Combination Subdivider 1

A stitch pattern combination can be subdivided into several sections. The subdivision is inserted below the cursor. Only the section in which the cursor is placed will be sewn. To sew the next section, the cursor must be placed in this section.

Prerequisite:

- A stitch pattern combination has been created.
- > Select the desired position within the stitch pattern combination where the stitch pattern combination is to be subdivided.



- > Tap «i-Dialog».



- > Tap «Edit Combination at Cursor Position».



- > Tap «Combination Subdivider (1)».

Stitch Pattern Combination Subdivider 2

A stitch pattern combination can be interrupted at different positions. The interruption is inserted below the cursor.

Prerequisite:

- A stitch pattern combination has been created.
- > Select the desired position within the stitch pattern combination where the stitch pattern combination is to be interrupted.



- > Tap «i-Dialog».



- > Tap «Edit Combination at Cursor Position».



- > Tap «Combination Subdivider (2)».
- > Sew stitch pattern combination up to the interruption and reposition the fabric.

Overwriting Stitch Patterns from the Personal Memory

Prerequisite:

- The stitch pattern is saved in the personal memory.

- > Select a stitch pattern, alphabet or buttonhole.
- > Edit the stitch pattern.
- > Tap «Personal Memory».



- > Tap «Save Stitch Pattern».
- > Select the file where the stitch pattern to be overwritten has been saved.
- > Select the stitch pattern which should be overwritten.



- > Tap «Confirm».

Loading Stitch Patterns from the Personal Memory

Prerequisite:

- The stitch pattern is saved in the personal memory.



- > Tap «Personal Memory».



- > Tap «Load Embroidery Design».
- > Select the file where the stitch pattern has been saved.
- > Select the stitch pattern.

Deleting Stitch Patterns from the Personal Memory

Prerequisite:

- The stitch pattern is saved in the personal memory.



- > Tap «Personal Memory».



- > Tap «Deleting».
- > Select the file where the stitch pattern has been saved.
- > Select the stitch pattern.



- > To delete the stitch pattern, tap «Confirm».

Saving Stitch Patterns on the BERNINA USB Stick

On the BERNINA USB stick stitch patterns, also those which have been individually edited, can be saved.

- > Select a stitch pattern or alphabet.
- > Editing stitch patterns.
- > Tap «Personal Memory».



- > Tap «Save Stitch Pattern».
- > Insert the BERNINA USB stick into the USB port of the machine.



- > Tap «USB Stick».



- > Tap «Confirm».

Uploading a Stitch Pattern from the BERNINA USB Stick



- > Tap «Personal Memory».



- > Tap «Load Embroidery Design».

- > Tap «Increasing/Decreasing the Display Size» (1).

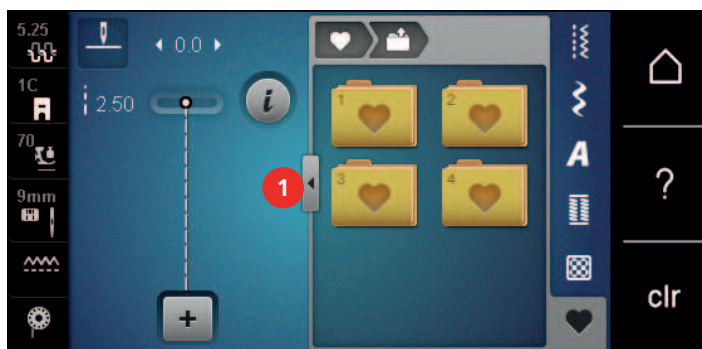

- > Insert the BERNINA USB stick into the USB port of the machine.
- > Tap «USB Stick».
- > Select the desired stitch pattern.

Deleting Stitch Patterns from the BERNINA USB Stick



- > Tap «Personal Memory».



- > Tap «Deleting».
- > Insert the BERNINA USB stick into the USB port of the machine.
- > Select the stitch pattern which is to be deleted.



- > Tap «Confirm».

5.8 Securing Stitches

Securing via the Icon «Securing»

Every single pattern of the stitch pattern combination can be secured at the start or at the end.



- > Tap «i-Dialog».



- > Tap «Edit Combination at Cursor Position».



- > Tap «Securing Stitches» before sewing is started.
 - The stitch pattern/stitch pattern combination is secured with 4 stitches at the beginning.
- > Tap «Securing Stitches» while sewing.
 - The stitch pattern or the active stitch pattern of the stitch pattern combination is secured with 4 stitches at the end.

Securing with the Button «Pattern End»

The «Pattern End» button can be programmed with various securing stitches.



- > Push the button «Pattern End» before sewing is started or while sewing.
 - While sewing, a stop icon indicates that the function is activated and the stitch pattern or the current combination of a stitch pattern will be secured at the end with the programmed number of stitches.

5.9 Height Compensation of Uneven Layers

If the presser foot is at an angle when sewing over a thick seam, the feed dog cannot grip the fabric and the sewing project cannot be sewn out properly.

- > Place 1 – 3 compensating plates as required from the back of the presser foot close to the needle to level the fabric layer.

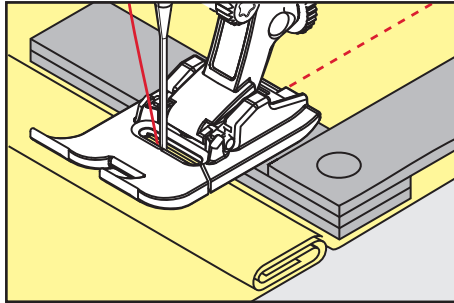

- The presser foot is leveled with the sewing project.

- > Place 1 – 3 compensating plates as required from the front of the presser foot close to the needle to level the fabric layer.

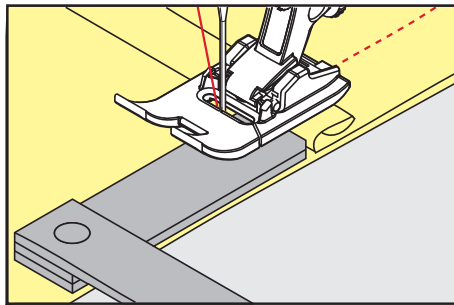

- The presser foot is leveled with the sewing project.

- > Sew until the complete presser foot has passed the thick seam.
- > Remove the plates of the height compensation.

5.10 Sewing Corners

When sewing corners, only a small section of the fabric is actually on the feed dog. Therefore it cannot grip the fabric well. By means of the height compensation tool the fabric can be fed evenly.

- > When the fabric edge is reached, stop the sewing process with needle position down.
- > Raise the presser foot.
- > Turn the fabric and place in desired position.
- > Place 1 – 3 compensating plates as required on the right of the presser foot close to the sewing project.
- > Lower the presser foot.

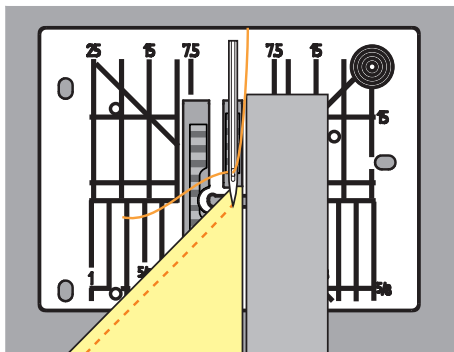







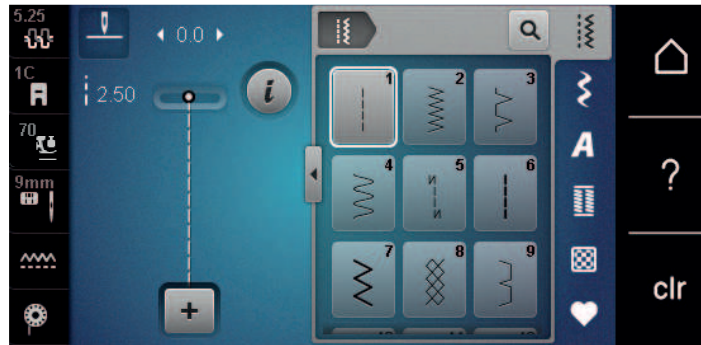







- > Resume sewing until the sewing project is on the feed dog again.









6 Practical Stitches

6.1 Overview Practical Stitches



Stitch patterns	Stitch number	Name	Description
---	1	Straight Stitch	To join seams, for topstitching and basting.
W	2	Zigzag	To finish edges, to sew elastic seams, to sew on lace inserts and elastics.
V	3	Vari-Overlock	For finishing edges, sewing together and simultaneously finishing elastic fabrics.
W	4	Running Stitch	For darning and reinforcing fabric edges or attaching lace or rubber tape.
N	5	Securing Program	For automatic securing at the start of the seam with forward and reverse stitches.
---	6	Triple Straight Stitch	For reinforced seams on heavy fabrics and decorative effects.
W	7	Triple Zig zag	For durable seams on strong fabrics, visible hems and decorative seams.
X	8	Honeycomb Stitch	For stretch fabrics and hems, including with rubber threads.
W	9	Blind Stitch	For blind hems on most fabric types and for shell edging on soft jerseys and fine fabric.
W	10	Double Overlock	For simultaneously sewing together and finishing elastic fabrics.
W	11	Superstretch Stitch	For highly stretch open seams.
W	12	Gathering Stitch	For gathering with rubber threads and for flat joining seams on medium-weight fabrics.

Stitch patterns	Stitch number	Name	Description
	13	Stretch Overlock	For simultaneously sewing together and finishing elastic fabrics, as well as for flat joining seams.
	14	Tricot Stitch	For visible hems and seams in lingerie and sweaters and for mending tricot fabric.
	15	Universal Stitch	For flat joining seams, visible hems and decorative seams in strong fabrics such as felt and leather and for attaching rubber tape.
	16	Sewn-out Zigzag	For finishing and reinforcing fabric edges, for sewing on rubber tape and for decorative seams.
	17	Lycra Stitch	For flat joining seams, visible hems on Lycra fabric and for stitching over seams in foundation garments.
	18	Stretch Stitch	For stretchable seams and hems in woven and knitted fabrics.
	19	Reinforced Overlock	For overlock seams or flat joining seams on medium-weight knit fabrics and toweling.
	20	Knit Overlock	For stretchable seams and hems in woven and knitted fabric, for sewing and finishing.
	22	Simple Darning Program	For automatic darning in fine to strong fabrics.
	23	Reinforced Darning Program	For automatic darning in strong materials.
	24	Bartack Program	For reinforcing pocket openings, buttonhole bars and for sewing belt loops.
	25	Bartack Program	For reinforcing pocket openings, sewing belt loops and securing seam ends.
	26	Large Fly Stitch	For reinforcing pocket openings, zippers and slits in medium-weight to thick fabrics.
	27	Small Fly Stitch	For reinforcing pocket openings, zippers and slits in fine to medium-weight fabrics.

Stitch patterns	Stitch number	Name	Description
	29	Narrow Blind Stitch	For blind hems and shell edging in light, fine and soft fabrics.
	30	Manual Basting Stitch	For work where a very long stitch length is required.
	32	Single Straight Stitch	As a connecting stitch in a combination for one straight stitch.
	33	Three Single Straight Stitches	As connecting stitches in a combination for three individual straight stitches.
	34	Darning Stitch	For darning together with the function "Permanent reverse sewing".
	35	Open Overlock Stitch	For simultaneously sewing together and finishing elastic fabrics with a reinforced edge.
	36	Overlock	For medium-weight knitted goods.
	37	Reinforced Overlock Stitch	For simultaneously sewing together, finishing and reinforcing elastic fabrics.

6.2 Sewing Straight Stitch

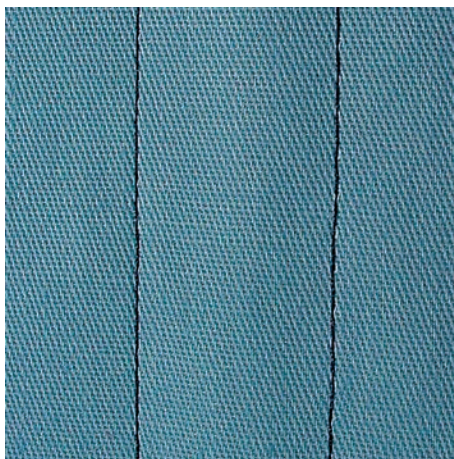

Adjust the stitch length for the sewing project, e.g. a long stitch for denim (approx. 3 – 4 mm) and a short stitch for delicate fabric (approx. 2 – 2.5 mm). Adjust the stitch length depending on the thread thickness, e.g. a long stitch (approx. 3 – 5 mm) for top-stitching with gimp.

Prerequisite:

- The Reverse Pattern Foot #1C/1D is fitted.



- > Tap «Practical Stitches».
- > Select Straight Stitch No. 1.

6.3 Securing with the Automatic Securing Program

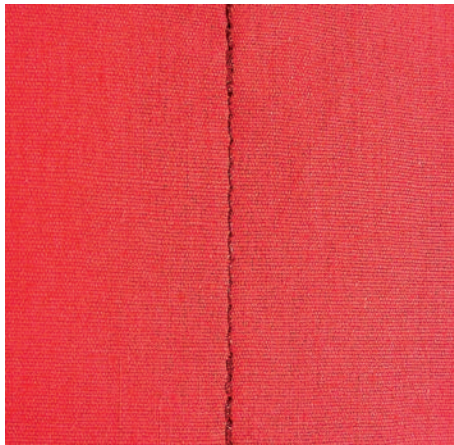

Due to a determined number of 6 stitches sewn forwards and 6 stitches sewn in reverse, the securing is regular.

Prerequisite:

- The Reverse Pattern Foot #1C is fitted.



- > Tap «Practical Stitches».
- > Select Securing Program No. 5.
- > Press the foot control.
 - The machine secures automatically.
- > Sew the seam at the desired length.



- > Push the button «Quick Reverse».
 - The machine secures automatically and stops at the end of the securing program.

6.4 Sewing in the Zipper

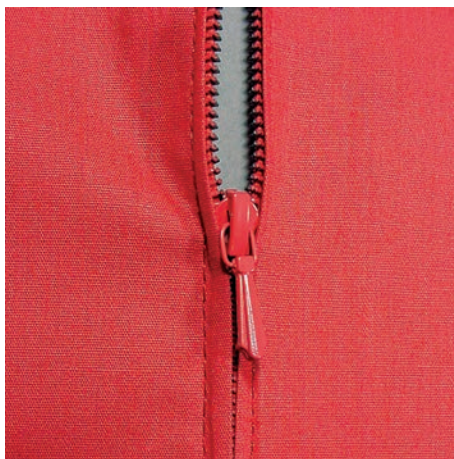

As the fabric feed can be difficult when starting to sew, it is recommended to hold the threads firmly or to pull the fabric slightly to the back for a few stitches or to sew 1 – 2 cm reverse first.



- > Fit the Reverse Pattern Foot #1C.
- > Tap «Practical Stitches».
- > Select Straight Stitch No. 1.
- > Sew the seam up to where the zipper starts.
- > Sew the securing stitches.
- > Close the zipper length with long stitches.
- > Finish the seam allowances.
- > Iron the seam.

- > Open the zipper length.
- > Baste the zipper under the fabric so that the fabric folded edges meet over the center of the zipper.
- > Open the zipper a few centimeters.
- > Fit the Zipper Foot #4D.
- > Move the needle position to the right.
- > Use the Free Hand System to raise the presser foot and to position the sewing project.
- > Start sewing from top left.
- > Guide the foot so that the needle stitches along the zipper coils.
- > Stop in front of the zipper pull with needle position down.
- > Raise the presser foot.
- > Close the zipper.
- > Continue to sew and stop in front of the base of the zipper with needle position down.
- > Raise the presser foot and turn the sewing project.
- > Sew across the other side of the zipper and stop with needle position down.
- > Raise the presser foot and turn the sewing project.
- > Sew the second side from bottom to top.

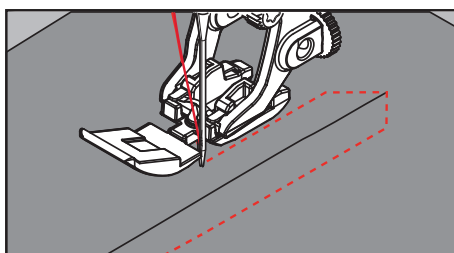

6.5 Sewing Both Sides of the Zipper from Bottom to Top

For fabrics with pile, such as velvet, it is recommended to sew in the zipper on both sides from bottom to top.



When the fabric is firm or densely woven, it is recommended to use a needle with the size 90 – 100. This results in an even stitch formation.



- > Fit the Reverse Pattern Foot #1C.
- > Tap «Practical Stitches».
- > Select Straight Stitch No. 1.
- > Sew the seam up to where the zipper starts.
- > Sew the securing stitches.
- > Close the zipper length with long stitches.
- > Finish the seam allowances.
- > Iron the seam.
- > Open the zipper length.
- > Baste the zipper under the fabric so that the fabric folded edges meet over the center of the zipper.
- > Fit the Zipper Foot #4D.
- > Move the needle position to the right.
- > Use the Free Hand System to raise the presser foot and to position the sewing project.
- > Start sewing in the center of the seam at the end of the zipper.
- > Sew diagonally along the edge of the zipper coils.
- > Sew the first side (1) from bottom to top.
- > Stop in front of the zipper pull with needle position down.
- > Raise the presser foot.
- > Open the zipper as far as behind the presser foot.
- > Lower the presser foot and continue sewing.
- > Move the needle position to the left.

- > Sew the second side (2) in exactly the same way from bottom to top.

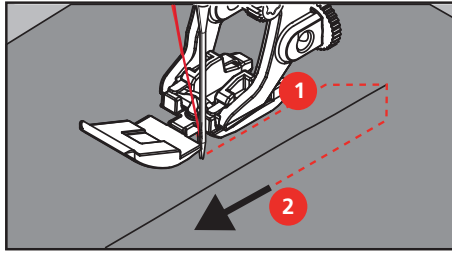

6.6 Sewing Triple Straight Stitch



The triple straight stitch is especially suitable for durable seams and for firm, densely woven fabrics such as denim and corduroy. For firm or densely woven materials, it is recommended to fit the Jeans Foot #8. This will help to sew denim or canvas. For decorative topstitching, the stitch length can be elongated.

- > Fit the Reverse Pattern Foot #1C/1D.
- > Tap «Practical Stitches».
- > Select Triple Straight Stitch No. 6.



6.7 Sewing Triple Zigzag

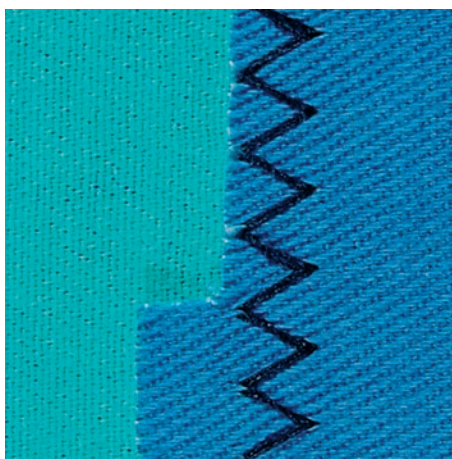

In firm fabrics, particularly for denim fabrics, deckchair covers, awnings. Hems on items that are frequently washed. Finish the seam edges first.

- > Fit the Reverse Pattern Foot #1C/1D.
- > Tap «Practical Stitches».
- > Select Triple Zig zag No. 7.



- > Turn the sewing project by 90°.
- > Sew the first rows not too close.

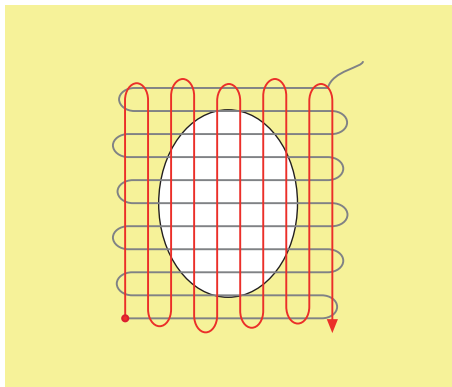

- > Turn the sewing project by 180°.
- > Sew another loose row.

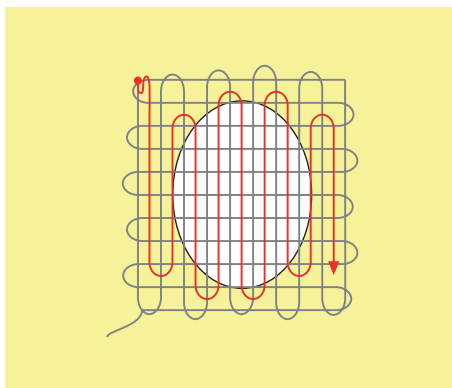

6.9 Automatic Darning



The Simple Darning Program No. 22 is particularly suitable for quick darning of worn areas or tears. It is recommended to use fine material as a backing for the worn and damaged areas or to stick an adhesive interlining. The Simple Darning Program No. 22 replaces the longitudinal threads in all fabrics. If the darning area becomes distorted, correct with the balance.

- > Fit the Reverse Pattern Foot #1C or Buttonhole Foot with Slide #3A.
- > Tap «Practical Stitches».
- > Select Simple Darning Program No. 22.
- > Hoop light-weight materials in the round embroidery hoop (optional accessory).
 - The darning area stays evenly taut and cannot be distorted.



6.11 Reinforced Darning

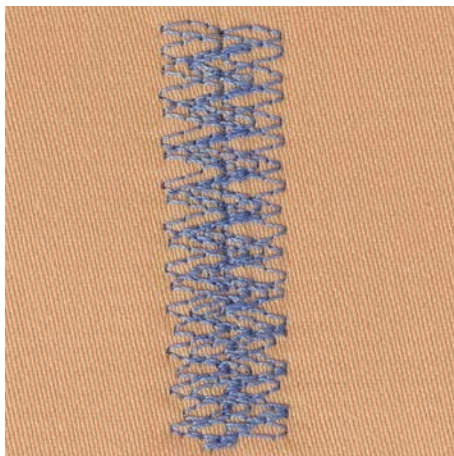

The Darning Stitch No. 34 is particularly suitable for damaged areas on heavy or strong fabrics, e. g. jeans and work clothes.

- > Fit the Reverse Pattern Foot #1C.
- > Tap «Practical Stitches».
- > Select Darning Stitch No. 34.
- > Sew the first row. Start at the top left.
- ⌋ > When the desired length is reached, push the button «Quick Reverse».
 - The machine sews in reverse.
- ⌋ > When the desired length is reached, push the button «Quick Reverse» again.
- > Repeat the process until the desired width is filled.

6.12 Finishing Edges



Zigzag No. 2 is suitable for all fabrics. It can be used for elastic seams as well as for decorative work. Use darning thread for fine materials. When sewing satin stitch, it is recommended to set a short, dense zigzag at a stitch length of 0.3 – 0.7 mm. The satin stitch can be used for appliqué and for embroidering.

Prerequisite:

- The edge of the fabric should lie flat and not roll.
- > Fit the Reverse Pattern Foot #1C.
- > Tap «Practical Stitches».
- > Select Zigzag No. 2 or Satin Stitch No. 1315.
- > Neither select too wide a stitch nor too long a stitch.
- > Guide the edge of the fabric into the center of the presser foot, so that the needle goes into the fabric on one side and over the edge into the air on the other side.



6.13 Sewing Double Overlock



A double overlock seam is suitable for loose knits and cross seams in knits. When working with jersey, a jersey needle should be used to prevent damaging the knit fabric. When sewing stretch materials, use a stretch needle.

- > Fit the Reverse Pattern Foot #1C or Overlock Foot #2A.
- > Tap «Practical Stitches».
- > Select Double Overlock No. 10.



6.14 Narrow Edgestitching

- > Fit the Blindstitch Foot #5 or Edgestitch Foot #10/10C/10D.
- > Tap «Practical Stitches».
- > Select Straight Stitch No. 1.
- > Place the edge against the left-hand guide of the Blindstitch Foot.
- > Select the left-hand needle position at the desired distance to the edge.

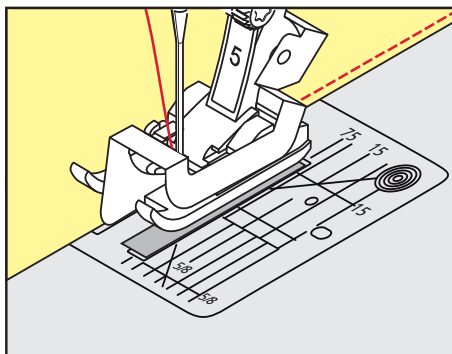

6.15 Wide Edgestitching

- > Fit the Reverse Pattern Foot #1C.
- > Tap «Practical Stitches».
- > Select Straight Stitch No. 1.
- > Guide the edge along the presser foot or at a distance of 1 – 2.5 cm along the marks on the stitch plate.



- > Select the needle position at the desired distance to the edge.

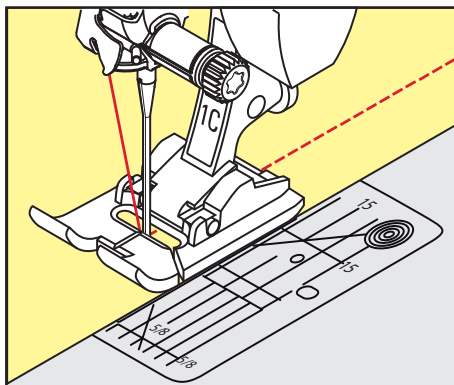

6.16 Edgestitching Using the Seam Guide

When sewing parallel wider lines, it is recommended to guide the seam guide (optional accessory) along a sewn line.

- > Fit the Reverse Pattern Foot #1C.
- > Tap «Practical Stitches».
- > Select Straight Stitch No. 1.
- > Loosen the screw on the back of the presser foot.
- > Insert the seam guide into the hole in the presser foot.
- > Adjust the width as required.
- > Tighten the screw.
- > Guide the folded edge along the seam guide.

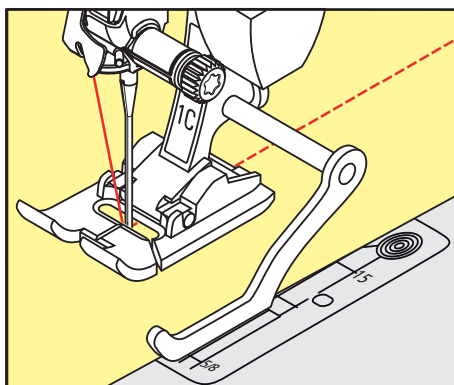

6.17 Sewing Hem Edges

When using the Blindstitch Foot #5, it is recommended to set the needle position to the far left or right. With the Reverse Pattern Foot #1C and Edgestitch Foot #10/10C/10D all needle positions are possible.

- > Fit the Blindstitch Foot #5 or the Reverse Pattern Foot #1C or the Edgestitch Foot #10/10C/10D.
- > Tap «Practical Stitches».
- > Select Straight Stitch No. 1.
- > Place the inner upper hem edge against the guide of the Blindstitch Foot on the right.



- > Select the needle position to the far right in order to sew along the upper edge.

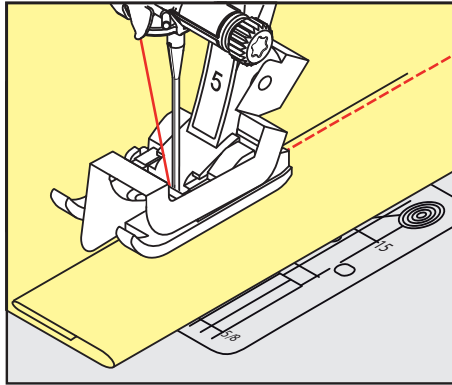

6.18 Sewing Blind Hems

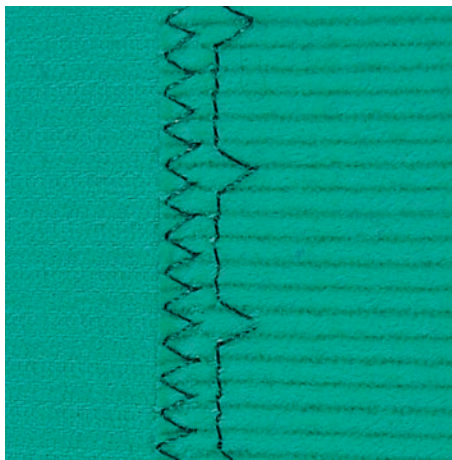

For invisible hems in medium to heavy weight cotton, wool and blended materials.

Prerequisite:

- The fabric edges are finished.
- > Fit the Blindstitch Foot #5.
- > Tap «Practical Stitches».
- > Select Blind Stitch No. 9.
- > Fold the fabric so that the finished fabric edge is on the right side.
- > Place the fabric under the presser foot and move the folded edge against the metal guide on the presser foot.
- > Guide the folded edge evenly along the metal guide of the presser foot to sew the stitches evenly deep.
 - Make sure that the needle only pierces the edge of the fold.
- > After sewing about 10 cm, check both sides of the fabric and adjust the width again if necessary.

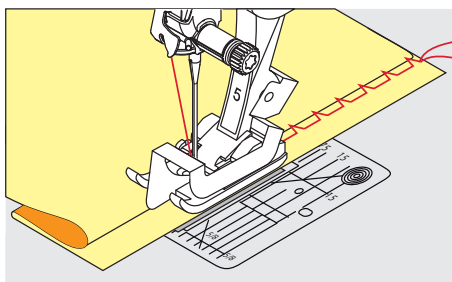

6.19 Sewing Visible Hems



The visible hem is particularly suitable for elastic seams in tricot made of cotton, wool, synthetic and mixed fibers.



- > Fit the Reverse Pattern Foot #1C/1D.
- > Tap «Practical Stitches».
- > Select Tricot Stitch No. 14.
- > Iron the hem and baste if necessary.
- > Reduce the presser foot pressure if necessary.
- > Sew the hem in the desired depth on the right side of the fabric.
- > Trim off the remaining fabric on the wrong side of the fabric.

6.20 Sewing Flat Joining Seams

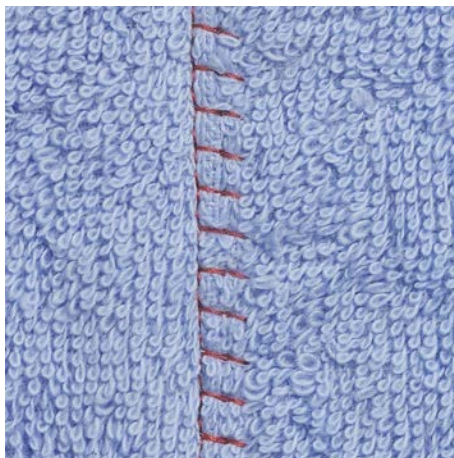

The flat joining seam is especially suitable for long-pile or thick materials such as terrycloth, felt or leather.



- > Fit the Reverse Pattern Foot #1C.
- > Tap «Practical Stitches».
- > Select Stretch Overlock No. 13.
- > Overlap the fabric edges.
- > Sew along the fabric edge.
- > To get a very flat, durable seam, make sure the needle stitches right over the top edge of the fabric into the bottom fabric.



7 Decorative Stitches

7.1 Overview Decorative Stitches

Easier or more difficult decorative stitches come into their own depending on the type of fabric.

- Decorative stitches which are programmed with single straight stitches are particularly appropriate for lightweight materials, e. g. Decorative Stitch No. 101
- Decorative stitches which are programmed with triple straight stitches or with a few satin stitches are particularly appropriate for medium-weight materials, e. g. Decorative Stitch No. 107
- Decorative stitches which are programmed with satin stitches are particularly appropriate for heavyweight materials, e. g. Decorative Stitch No. 401

For a perfect stitch formation, it is of advantage to use the same thread color for upper and bobbin thread and a stabilizer. With pile or longfiber materials, it is recommended to use an additional water-soluble stabilizer, which can be easily removed after sewing, on the right side of the fabric.



Decorative Stitch	Category	Name
	Category 100	Nature Stitches
	Category 300	Cross Stitches
	Category 400	Satin Stitches
	Category 600	Geometric Stitches
	Category 700	Heirloom Stitches
	Category 900	Children Stitches
	Category 1100	Special Stitches
	Category 1700	International
	Category 2000	Seasons

7.2 Bobbin-Play

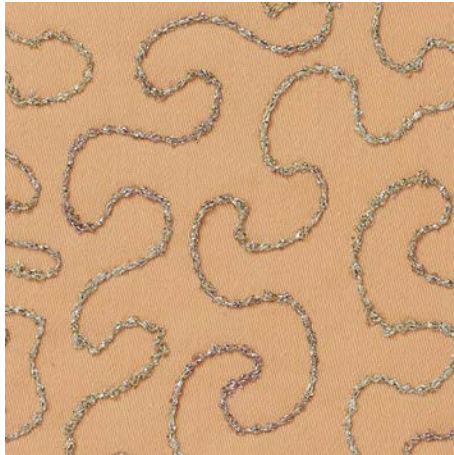

The bobbin can be filled with different thread material. For free-motion stitching to add texture. This method is similar to "normal" free-motion sewing, but is done on the **wrong** side of the fabric.

Reinforce the area to be sewn with embroidery stabilizer. The design can be drawn on the wrong side of the fabric. You can also draw the design on the front side of the fabric. The lines can be followed with a freely guided straight stitch using polyester, cotton or rayon thread. The rows of stitching are visible on the wrong side of the fabric, and they serve as guidelines for the bobbin-thread sewing.

The BSR function can be used for bobbin-thread sewing. We recommend guiding your project evenly under the needle at a consistent speed, following the lines of the design. The stabilizer must be removed after sewing.

Sew a sample first to check what the result looks like on the wrong side of the fabric.

Not all decorative stitches are suitable for this technique. Simple decorative stitches provide best results. Avoid compact stitch types and satin stitches.

NOTICE

Inappropriate Bobbin Case is Used

Damage to the bobbin case.

> Use the bobbinwork bobbin case (optional accessory).



> Fit the Open Embroidery Foot #20C/20D.

> Tap «Decorative Stitches».

> Select an appropriate decorative stitch.

> Turn the «Upper Multifunction Knob» and the «Lower Multi-function Knob» to set the stitch length and stitch width so that a beautiful stitch formation can be achieved even when sewing with thick thread.



> To adjust the upper thread tension, tap «Upper Thread Tension».

7.3 Sewing Cross Stitches

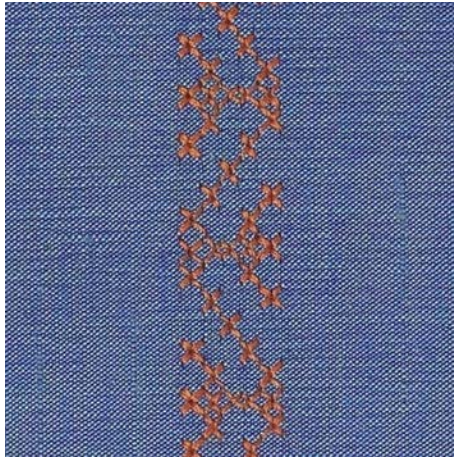

Cross stitch embroidery is a traditional technique and an addition to the other decorative stitches. If the cross stitches are sewn on fabrics with a linen structure, they look as if they were hand-stitched. When cross stitches are sewn with embroidery yarn, the stitch pattern appears fuller. Cross stitches are particularly used for home furnishing, trimmings on garments and embellishing in general. As every following line refers to the first row, it is important to stitch the first row in a straight line.

- > Fit the Reverse Pattern Foot #1C/1D or Open Embroidery Foot #20C/20D.
- > Select a cross stitch of the Category 300 and combine it as desired.
- > Stitch the first row using the seam guide to sew a straight line.
- > Stitch the second row next to the first at a distance of one presser foot's width or using the seam guide.

7.4 Pintucks

Pintucks



Pintucks are narrow stitched folds, which are normally sewn on the fabric before cutting out the pieces for the garment or the sewing project. They are suitable for embellishing or in combination with other heirloom embroidery techniques. The use of Pintuck Feet can simplify this technique considerably. The technique reduces the size of the fabric piece. It is always advisable to plan in sufficient fabric.

Overview Pintuck Feet

Pintuck Foot	Number	Description
	#30 (optional accessory)	3 grooves For heavy-weight fabrics. In combination with the 4 mm twin needle
	#31 (optional accessory)	5 grooves For heavy to medium-weight fabrics. In combination with the 3 mm twin needle
	#32 (optional accessory)	7 grooves For light to medium-weight fabrics. In combination with the 2 mm twin needle
	#33 (optional accessory)	9 grooves For very light fabrics (without extra cord). In combination with the 1 or 1.6 mm twin needle
	#46C (optional accessory)	5 grooves In combination with the 1.6 – 2.5 mm twin needle For very light to medium-weight fabrics.

Working with Cord

The pintucks look more distinctive and relief-like when they are sewn with a supplementary cord. Choose a cord that fits well into the grooves of the respective foot. The cord must be colorfast and shrink-proof.

- > Switch off the machine.
- > Remove the needle.
- > Remove the presser foot.
- > Remove the stitch plate.
- > Open the hook cover.
- > Pull the cord through the hook opening from the bottom and through the opening of the stitch plate.
- > Replace the stitch plate.
- > Close the hook cover.
- > Make sure that the cord slides through the thread slot of the bobbin cover.

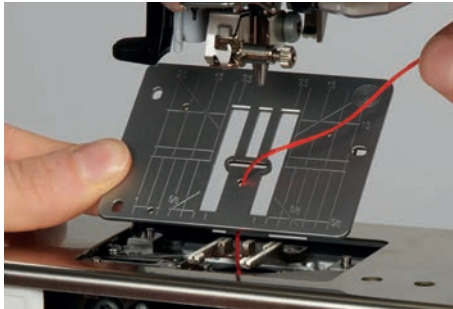

- > Place the spool on the knee lifter.

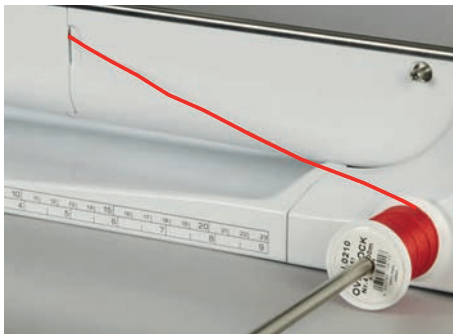

- > Check that the cord runs smoothly.
- > If the thread doesn't glide smoothly at the hook cover, leave the hook cover open.
- > If the hook cover is opened, deactivate the lower thread indicator in the Setup Program.
 - The cord lies on the wrong side of the material and is hold/sewn over by the bobbin thread.

8 Alphabets

8.1 Overview Alphabet

Block- outline, script, quilt and comic writing, as well as Cyrillic and Cyrillic script can be sewn in two different sizes. Block- outline, script, quilt and comic writing, as well as Cyrillic and Cyrillic script can also be sewn in small letters.

For a perfect stitch formation, it is recommended to use the same thread color for upper and bobbin threads. The fabric can be reinforced with embroidery stabilizer on the wrong side. When working with pile or napped fabrics, e.g. toweling, use an additional, water-soluble stabilizer on the right side of the fabric.

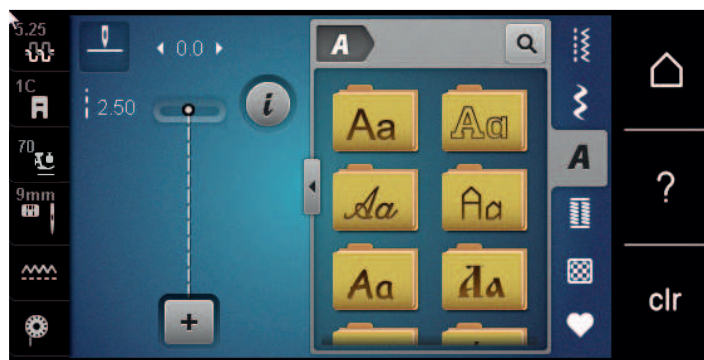

Stitch Pattern	Name
ABCabc	Block alphabet
ABCabc	Double-Block
<i>ABCabc</i>	Script (Italics)
ABCabc	Quilt Text
ABCabc	Comic
АБВабв	Cyrillic
<i>АБВ абв</i>	Cyrillic script
あいう	Hiragana

8.2 Creating Lettering



Sewing a test sample with the thread, the actual fabric and stabilizer you intend to use is recommended. Make sure that the fabric is fed evenly and lightly, ensuring that it cannot push against or catch on anything. The fabric shouldn't be pulled, pushed or held back.



- > Tap «Alphabets».
- > Select the font.



- > To create a combination, tap «Combination Mode/Single Mode».

- > To open the extended Enter Mode, tap «Increasing/Decreasing the Display Size» (1).



- > Select the letters.



- > To use upper-case letters, tap «Upper Case Characters» (standard setting).



- > To use lower-case letters, tap «Lower Case Characters».



- > To use figures and mathematical symbols, tap «Numbers and Mathematical Characters».



- > To use special characters, tap «Special Characters».



- > To delete individual syllables of the entered text, tap «Deleting».
- > To close the extended Enter Mode, tap «Increasing/Decreasing the Display Size» again.

8.3 Alter Font Size

Block- outline, script, quilt and comic writing, as well as Cyrillic and Cyrillic script can be scaled down in single mode.



- > Tap «Alphabets».
- > Select the font.
- > Select the letters.



- > Tap «i-Dialog».











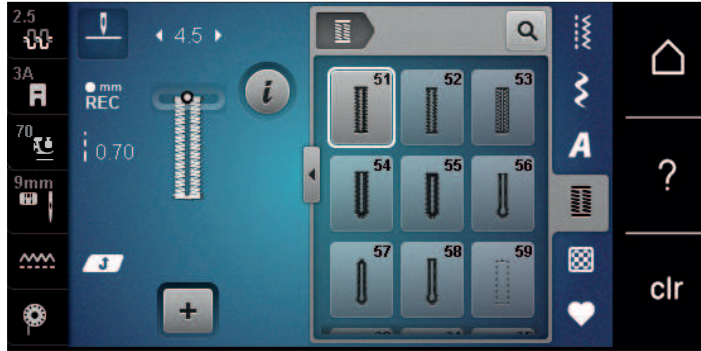

- > To reduce the font size, tap «Alter Font Size».
- > To scale up the font size to 9 mm, tap «Alter Font Size» again.







9 Buttonholes

9.1 Overview Buttonholes

To be able to create the right buttonhole for every button, every purpose and also for every garment, the BERNINA 570 QE comes with an extensive collection of buttonholes. The corresponding button can be sewn on automatically. Eyelets can also be sewn.



Stitch patterns	Stitch number	Name	Description
	51	Standard Buttonhole	For light to medium-weight fabrics. e.g. blouses, dresses and bed linen.
	52	Narrow Standard Buttonhole	For light to medium-weight fabrics, e.g. blouses, dresses, children's and baby clothes, crafts.
	53	Stretch Buttonhole	For all elastic fabrics.
	54	Round Buttonhole with Normal Bartack	For medium-weight to heavy fabrics. e.g. dresses, jackets, coats and rainwear.
	55	Round Buttonhole with Horizontal Bartack	For medium-weight to heavy fabrics, with a reinforced bar, e.g. dresses, jackets, coats and rainwear.
	56	Keyhole Buttonhole	For heavy, non-stretch fabrics, e.g. jackets, coats and leisurewear.
	57	Keyhole Buttonhole with Pointed Bartack	For stronger, non-stretch fabrics, e.g. jackets, coats, jeans and leisurewear.
	58	Keyhole Buttonhole with Horizontal Bartack	For strong, non-stretch fabrics, e.g. jackets, coats and leisurewear.
	59	Straight Stitch Buttonhole	For staystitching and reinforcing buttonholes and as button hole edging, especially for buttonholes in leather and imitation leather.
	60	Button Sew-on Program	Sews buttons with 2 or 4 holes.

Stitch patterns	Stitch number	Name	Description
	61	Eyelet with Small Zigzag	Openings for cords or narrow ribbons and for decorative work.
	62	Eyelet with Straight Stitch	Openings for cords or narrow ribbons and for decorative work.
	63	Heirloom Buttonhole	For handlook stitching effects on clothes and handicrafts on light to medium-weight fabrics.
	64	Double-rounded Buttonhole	For medium-weight to heavy fabrics made from different fabrics.
	65	Double-rounded Heirloom Buttonhole	For light to medium-weight woven fabrics, e.g. blouses, dresses and bedlinen.
	67	Round Buttonhole with Bartack	For medium-weight woven fabrics, e.g. blouses, dresses and jackets.
	69	Decorative Buttonhole with Double Pointed Bartack	For decorative buttonholes in firmer, non-elastic fabrics.

9.2 Making Use of the Height Compensation Tool

When a buttonhole is to be sewn at right angles to the project edge, it is recommend to use the height compensation plates (optional accessory).

- > Place the plates from the back between the sewing project and the bottom of the slide to the thick part of the sewing project.

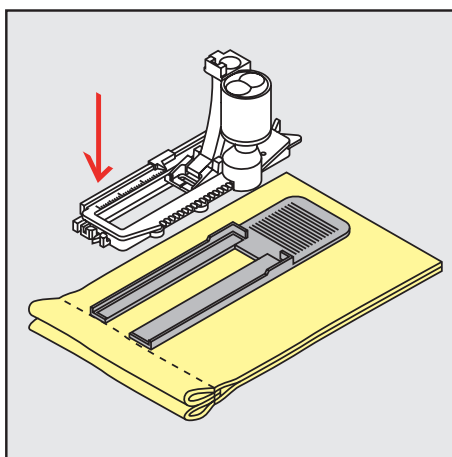

- > Lower the presser foot.

9.3 Using the Compensation Plate

For sewing a buttonhole in problematic fabrics, it is recommended to use the Height Compensation Tool (optional accessory). The Height Compensation Tool can be used in combination with the Buttonhole Foot with Slide #3A.

- > Insert the compensation plate carefully from the side.

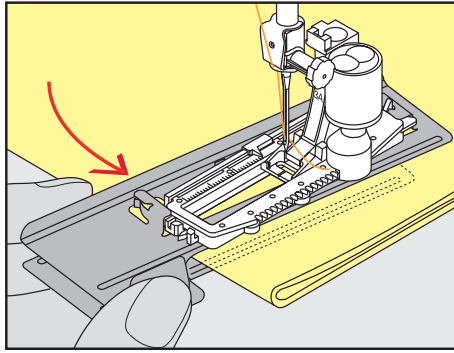

9.4 Marking Buttonholes

- > For the buttonholes to be sewn manually, mark the position and the length on the fabric using chalk or a water-soluble pen.

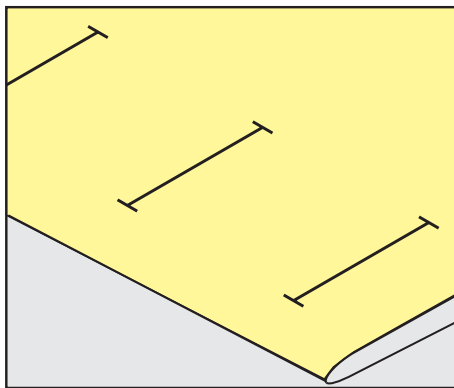

- > For the buttonholes to be sewn automatically, mark the complete length of 1 buttonhole on the fabric using chalk or a water-soluble pen. For any subsequent buttonholes mark the starting point.

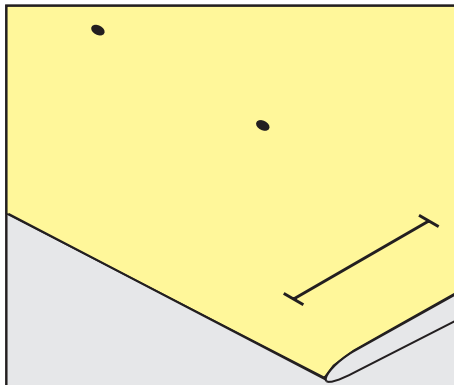

- > For keyhole and round buttonholes mark the length of the bead with chalk or a water-soluble pen on the fabric. For any subsequent buttonholes mark the starting point. The length of the keyhole is sewn additionally.

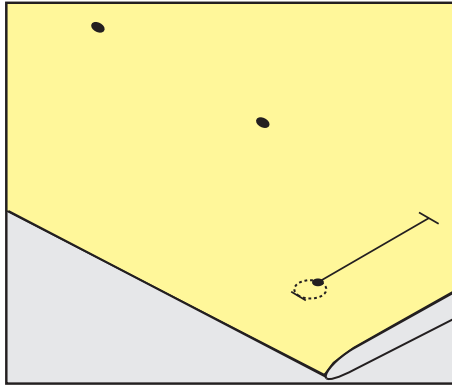

9.5 Cord

Using Cord with the Buttonhole Foot with Slide #3A

The additional cord reinforces and embellishes the buttonhole and is particularly suitable for the Buttonhole No. 51. Ideal cords are Perle cotton No. 8, strong hand-sewing thread and fine crochet yarn. It is recommended to not hold the cord while sewing.

Prerequisite:

- The Buttonhole Foot with Slide #3A is fitted and raised.
- > Insert the needle at the beginning of the buttonhole.
- > Guide the cord on the right side under the Buttonhole Foot with Slide.
- > Hook the cord over the pin at the back of the Buttonhole Foot with Slide.

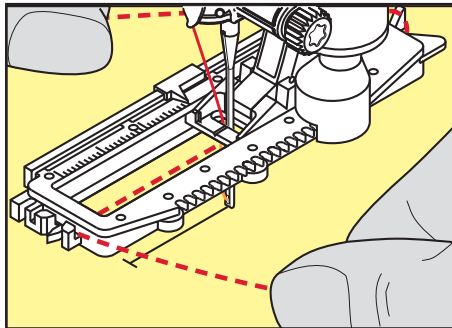

- > Pull the cord on the left side under the Buttonhole Foot with Slide to the front.

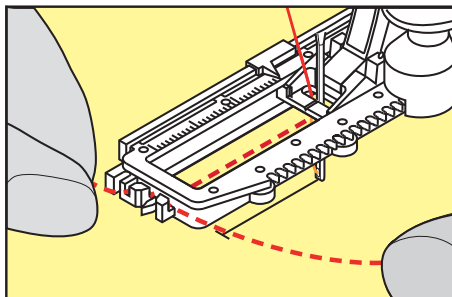

- > Pull the cord ends into the slits.
- > Lower the Buttonhole Foot with Slide.
- > Sew the buttonhole in the usual manner.
- > Pull the cord loop until the loop disappears in the bartack.

- > Pull the cord ends with the sewing needle to the back and knot or secure them.

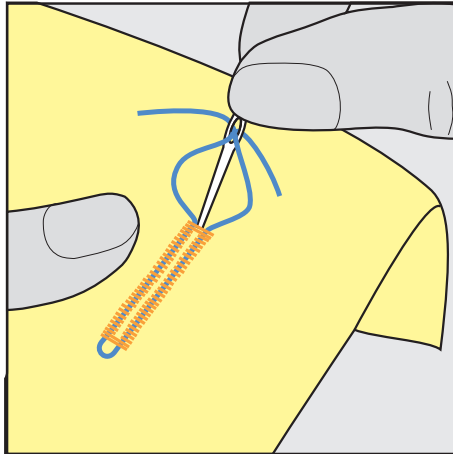

9.6 Sewing a Test Sample

Always sew a test sample of the buttonhole on the same fabric: It is recommended to use the same stabilizer and to select the same buttonhole. The test sample should also be sewn in the respective direction. By sewing a test sample the settings can be adjusted until the sewing result is satisfying.

It is worth underlaying the buttonholes with the Straight Stitch Buttonhole No. 59 when working with soft loosely woven materials and for buttonholes which are severely strained. This is also recommended to reinforce buttonholes in leather, vinyl or felt.

Alterations of the Balance when sewing a manual standard buttonhole as well as the Keyhole and the Round Buttonhole affect both beads in the same way. With the manual keyhole or round buttonhole, the alterations affect both sides in the opposite way.

If the Stitch Counter function is used, and alterations are made concerning the Balance, the alterations affect both buttonhole beads differently.



- > Tap «Buttonholes».
- > Select the buttonhole.
- > Select and fit the desired presser foot.
- > Place the fabric under the presser foot and lower the presser foot.
- > Press the foot control carefully and start sewing. Guide the fabric slightly.
- > Check the Balance while sewing and adjust if necessary.
- > Check the test sample and make further amendments if necessary.

9.7 Determining the Buttonhole Slit Width

The width of the buttonhole slit can be adjusted between 0.1 – 2.0 mm before sewing.



- > Tap «Buttonholes».
- > Select the buttonhole.



- > Tap «i-Dialog».



- > Tap «Buttonhole Slit Width».
- > To adjust the desired width of the buttonhole slit, turn the Upper Multi-function Knob or the «Lower Multi-function Knob».

9.8 Determining the Buttonhole Length with the Buttonhole Foot with Slide #3A



The button can be centered in the yellow circle on the display. By turning the «Upper/Lower Multifunction knobs», the yellow circle can be enlarged or downsized to determine the diameter of the button.

2 mm is automatically added to the diameter of the button for the buttonhole length. If the diameter of the button is 14 mm, for example, 16 mm is calculated for the buttonhole length.

Prerequisite:

- The Buttonhole Foot with Slide #3A is fitted.



- > Tap «Buttonholes».
- > Select the buttonhole.



- > Tap «i-Dialog».



- > Tap «Direct Entry Buttonhole Length».
- > Turn the «Upper Multi-function Knob» or the «Lower Multi-function Knob» to adjust the buttonhole length.

9.9 Determining the buttonhole length with Buttonhole Foot #3C

When the Buttonhole Foot #3C is used, the buttonhole length must be determined via the function Stitch Counter. The stitch counter function is suitable for all types of buttonholes. The left buttonhole bead is sewn forward, the right buttonhole bead is sewn in reverse. If alterations are made to the balance, the stitch counter function has to be saved for every buttonhole separately.

Prerequisite:

- The Buttonhole Foot #3C is fitted.



- > Tap «Buttonholes».
- > Select the buttonhole.



- > Tap «i-Dialog».



- > Tap «Programming the Length via the Stitch Counter».
- > Sew the desired length of the buttonhole.
- > Stop the machine.



- > The machine sews the lower bartack and the second bead in reverse when the button «Quick Reverse» is pushed.
- > Stop the machine at the height of the first stitch.
- > The machine sews the upper bartack and the securing stitches when the button «Quick Reverse» is pushed again.
 - The length of the buttonhole remains saved and every subsequent buttonhole is sewn identically until the machine is switched off.

9.10 Sewing a Buttonhole Automatically

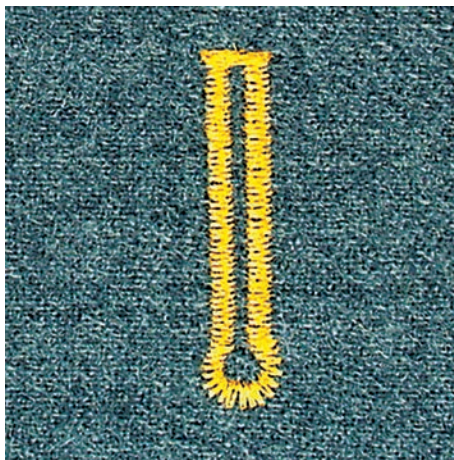
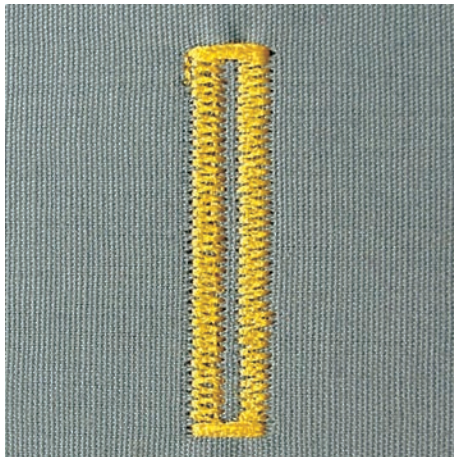

When the Buttonhole Foot with Slide #3A is used, the length of the buttonhole is measured automatically by the lens on the presser foot. The buttonhole will be exactly duplicated and the machine switches to the next step automatically when the maximum length is reached. The Buttonhole Foot with Slide #3A is suitable for buttonholes at a length of 4 – 31 mm, depending on the buttonhole type. The Buttonhole Foot with Slide #3A must lie perfectly flat on the fabric so that the length can be measured accurately. Programmed buttonholes are all at the same length and of the same nice look.

Prerequisite:

- The Buttonhole Foot with Slide #3A is fitted.



- > Tap «Buttonholes».
- > Select the buttonhole.
- > Sew the desired length of the buttonhole.



- > To program the length, push the button «Quick Reverse».



- > Push the button «Start/Stop» or press the foot control.
 - The machine finishes the buttonhole automatically. All subsequent buttonholes are sewn at the same length.

9.11 Programming the Heirloom Buttonhole

Prerequisite:

- The Buttonhole Foot with Slide #3A is fitted.



- > Tap «Buttonholes».
- > Select Heirloom Buttonhole No. 63.
- > Sew the desired length of the buttonhole.

- > To program the length, push the button «Quick Reverse».
 - The machine finishes the buttonhole automatically. All subsequent buttonholes are sewn at the same length.

9.12 Sewing the manual 7-step buttonhole with the Buttonhole Foot #3C

The length of the buttonhole is determined manually when sewing. The bartack, eye and securing stitches are preprogrammed. The individual steps can also be selected by scrolling using the arrow icons or by pressing the button «Quick Reverse».

Prerequisite:

- The Buttonhole Foot #3C is fitted.



- > Tap «Buttonholes».
- > Select Standard Buttonhole No. 51.



- > Tap «i-Dialog».



- > Tap «Manual Length Adjustment».
 - Step 1 is activated in the display to start the buttonhole.
- > Sew the desired length of the buttonhole.
 - Step 2 is activated.

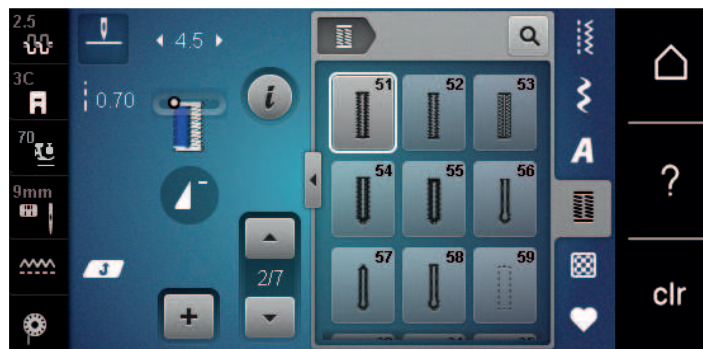

- > Stop when the required length of the buttonhole or the length marking is reached.
- > Step 3 appears by tapping «Scroll Down».
 - The machine sews straight stitches in reverse.
- > Stop at the height of the first stitch at the start of the buttonhole.
- > Step 4 appears by tapping «Scroll Down».
 - The machine sews the upper bartack and stops automatically.
- > Step 5 appears by tapping «Scroll Down».
 - The machine sews the second bead.
- > Stop the machine at the level of the last stitch of the first bead.
- > Step 6 appears by tapping «Scroll Down».
 - The machine sews the lower bartack and stops automatically.
- > Step 7 appears by tapping «Scroll Down».
 - The machine secures and stops automatically.

9.13 Sewing the Manual 5-step Buttonhole with the Buttonhole Foot #3C

The length of the buttonhole is determined manually when sewing. The bartack, eye and securing stitches are preprogrammed. The individual steps can also be selected by scrolling using the arrow icons or by pressing the button «Quick Reverse».

Prerequisite:

- The Buttonhole Foot #3C is fitted.

- > Tap «Buttonholes».
- > Select Round Buttonhole with Normal Bartack No. 54.
- > Tap «i-Dialog».
- > Tap «Manual Length Adjustment».
 - Step 1 is activated in the display to start the buttonhole.
- > Sew the desired length of the buttonhole.
 - Step 2 is activated.



- > Stop when the required length of the bead or the length marking is reached.
- > Step 3 appears by tapping «Scroll Down».
- > The machine sews the curve or eye and stops automatically.
- > Step 4 appears by tapping «Scroll Down».
 - The machine sews the second bead in reverse.
- > Stop the machine at the level of the first stitch where the buttonhole begins.
- > Step 5 appears by tapping «Scroll Down».
 - The machine sews the upper bartack and secures automatically.

9.14 Cutting the Buttonhole Open with the Seam Ripper

- > Place a pin in each end of the buttonhole to avoid accidental cutting into ends of buttonhole.
- > Cut the buttonhole from both ends to the middle.

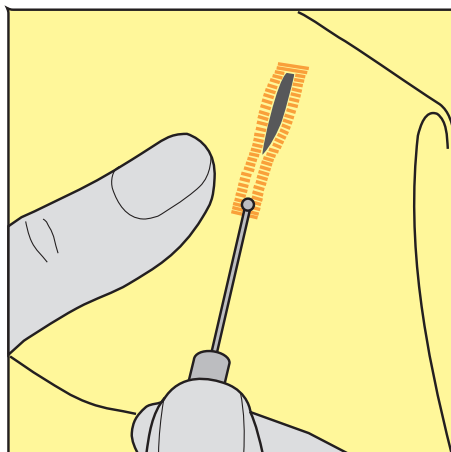

9.15 Cutting Open Buttonholes with the Buttonhole Cutter (Optional Accessory)

- > Place the fabric on an appropriate wood.

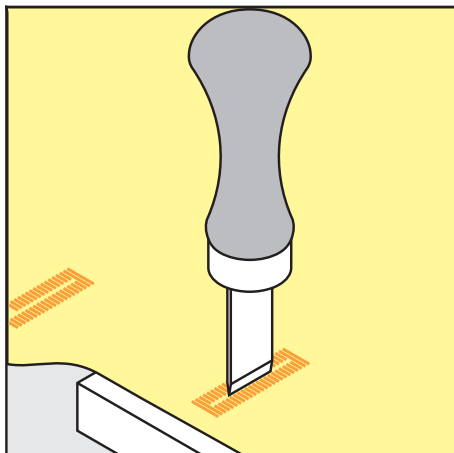

- > Position the cutter in the center of the buttonhole.
- > Press down on the cutter with your hand.

9.16 Sewing on a Button

The Button sew-on Program can be used to sew on buttons with two or four holes, press studs or snap fasteners.

Recommended sewing program: Button Sew-on Program No. 60

Recommended presser foot : Button Sew-On Foot #18

Alternative presser feet:

- Reverse Pattern Foot #1/1C
- Darning Foot #9
- Reverse Pattern Foot with Clear Sole #34/34C

Adjusting the Thread Shank

For buttons on thicker fabrics, increase the thread shank = the distance between the button and the fabric. Buttons sewn on thin fabrics or buttons for decorative purposes only are stitched without a «thread shank».

NOTICE! The adjustment of the thread shank is only possible when using the Button Sew-On Foot #18.

- > Loosen the screw on the back of the presser foot.
- > Push the bar upwards according to the thickness of the fabric.
- > Tighten the screw.

Sewing on a Button

Prerequisite:

- The shank length is adjusted according the fabric thickness.
- The Button Sew-On Foot #18 or an alternative presser foot is fitted.
- The fitted presser foot has been selected in the user interface.
- The feed dog is lowered.



- > Tap «Buttonholes».
- > Select Button Sew-on Program No. 60.
- > Turn the handwheel until the bobbin thread comes up.

10 Quilting

10.1 Overview Quilt Stitches

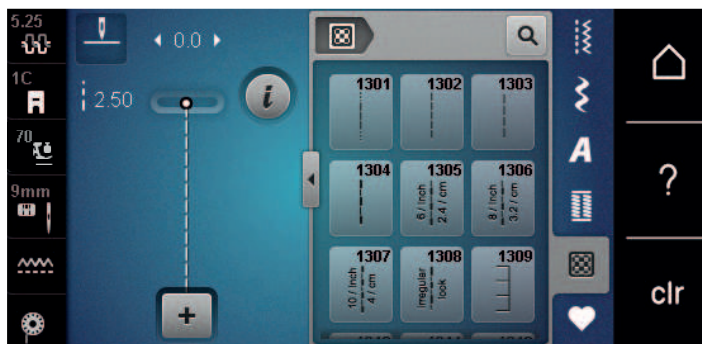

Stitch Pattern	Stitch Number	Name	Description
.....	No. 1301	Quilting, Securing Program	To secure at the sewing start and sewing end with short stitches forward.
-----	No. 1302	Quilting, Straight stitch	For machine quilting using a straight stitch with a 3 mm stitch length.
-----	No. 1303	Piecing stitch/Straight stitch	For sewing patchwork parts together using a straight stitch with a 2 mm stitch length.
-----	No. 1304 – No. 1308	Hand-look Quilt Stitch	For attaching an imitation of hand-look stitch with monofilament.
┌┐┌	No. 1309 – No. 1314	Blanket Stitch	For appliqués and sewing on ribbons.
Ψ	No. 1317 – No. 1327 No. 1329 – No. 1330 No. 1339 – No. 1346 No. 1363 – No. 1371 No. 1373 – No. 1394	Decorative Quilt Stitch	For quilting, crazy patchwork, embellishing and finishing.
	No. 1315	Satin Stitch	For appliqué.
~	No. 1316	Narrow Blind Stitch	For hidden sewing of applications.
⋄⋄⋄	No. 1331	Stippling Stitch/ Stippling Quilt Stitch	For imitations of stippling stitch.

Stitch Pattern	Stitch Number	Name	Description
	No. 1332 – No. 1338	Feather Stitch	For quilting, crazy patchwork, embellishing and finishing.

10.2 Quilting, Securing Program

Prerequisite:

- The Reverse Pattern Foot #1C is fitted.



- > Tap «Quilt Stitches».
- > Select Quilting, Securing Program No. 1301.
- > Press the foot control.
 - The machine sews 6 stitches forward automatically when sewing is started.
- > Sew the seam at the desired length.



- > Push the button «Quick Reverse».
 - The machine sews 6 stitches forward automatically and stops automatically at the end of the Securing Program.

10.3 Sewing Handlook Quilt Stitches

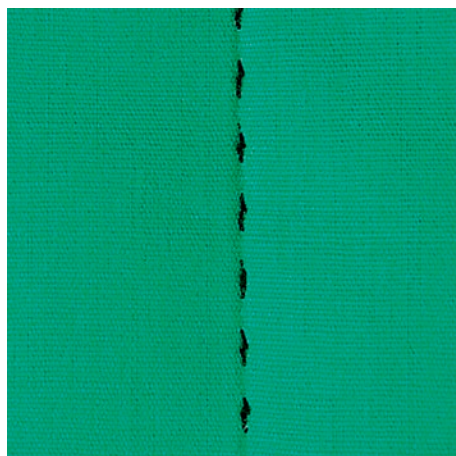

Hand-look quilt stitches are suitable for all fabrics and sewing projects that should look like hand-sewn. It is recommended to use a monofilament thread as upper thread and an embroidery thread as bobbin thread. The sewing speed should be moderate to prevent the monofilament from breaking. If required, the upper thread tension and the balance can be adjusted to the sewing project and the desired quilt stitch.

Prerequisite:

- The Reverse Pattern Foot #1C is fitted.



- > Tap «Quilt Stitches».
- > Select a Hand-look Quilt Stitch No. 1304 – No. 1308.
- > If necessary, adjust the upper thread tension and the Balance to suit the sewing project and the desired quilt stitch.
- > To start the machine, press the foot control or push the button «Start/Stop».

10.4 Guiding the Quilt Work Freely



Freehand quilting and darning use the same principle of free movement. With stipple quilting, entire surfaces of the fabric are filled with quilt stitches. The single lines of stitching are rounded and never cross one another.



- Quilting gloves with rubber nubs make it easier to guide the fabric.
- For the best possible results use the High Thread Tension Bobbin Case (optional accessory).
- It is recommended to use the slide-on table and the Free Hand System.
- With free motion quilting, it is of advantage to quilt from the center outwards and to guide the fabric using smooth, round movements to form the design of your choice.

Prerequisite:

- The top layer, the batting and the backing are pinned together or basted.
- The feed dog is lowered.
- The Darning Foot #9 is fitted.



- > Tap «Practical Stitches».
- > Select Straight Stitch No. 1.
- > If required, adjust the upper thread tension.
- > To prevent the fabric from shifting, select the needle position down.
- > To start the machine, press the foot control or push the button «Start/Stop».
- > Hold both hands close to the presser foot like an embroidery hoop to guide the fabric. Make sure that the needle does not pierce the same place several times in a row.
- > To ensure a minimum stitch distance when quilting corners, reduce the embroidery speed.
- > If the thread is lying on top of the fabric, slow down the movement.
- > If there are knots on the wrong side of the fabric, move the fabric more quickly.

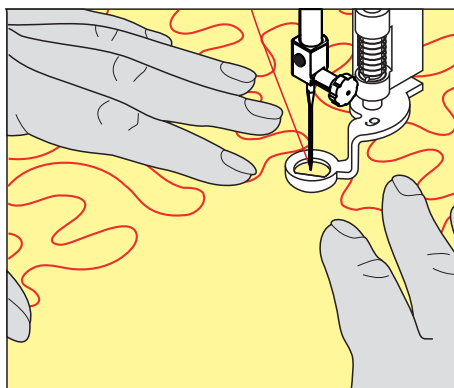

11 BERNINA Stitch Regulator (BSR)

The BERNINA Stitch regulator equalizes the stitch length which results of the free movement of the fabric while free-motion sewing - a sewing technique which grows more and more popular. When free-motion sewing with the BSR presser foot, every stitch is equally long and the stitch formation is perfectly regular.

As soon as the BSR presser foot is attached and the feed dog is lowered, the selection menu of the desired mode appears in the display of the machine. The BSR presser foot can be used with sewing straight stitch as well as zig zag.

The BSR presser foot reacts on the movement of the fabric and therefore controls the speed of the machine up to the highest possible speed. It can be said: The faster the movement of the material, the higher the speed of the machine.

If the fabric is moved too quickly, an acoustic signal sounds. The beeper can be activated or deactivated in the «BSR» display. The sound of the beeper can also be activated or deactivated in the Setup Program.

11.1 BSR Mode 1

The BSR function can be controlled via the foot control or the button «Start/Stop». Start the BSR mode. At the BSR presser foot a red light is on. By moving the fabric the machine accelerates. If the fabric isn't moved, securing in place is possible without pressing an additional button. When working via the foot control or when using the button «Start/Stop», the BSR mode doesn't stop automatically.

11.2 BSR Mode 2

The BSR function can be controlled via the foot control or the button «Start/Stop». The machine starts only when the foot control or the button «Start/Stop» is pressed and the fabric is moved simultaneously. Without moving the fabric, the BSR2 mode stops after 7 seconds. The red light goes off (only when working with the button «Start/Stop»). When working via the foot control, the red light doesn't go off.

11.3 BSR Function with Straight Stitch No. 1

This function allows free-motion quilting with straight stitch and a pre-programmed stitch length up to 4 mm. The programmed stitch length is maintained within a certain speed, independent of the fabric movement.

11.4 BSR Function with Zigzag No. 2

The zig zag can be used e.g. for thread painting. The set stitch length will **not** be maintained when sewing the zig zag stitch, but the BSR function simplifies the application. Anwendung.

11.5 Sewing Preparations for Quilting

Attach the BSR Presser Foot

Prerequisite:

- The machine is switched off.
 - The needle is raised.
 - The presser foot is raised.
- > Remove the fitted presser foot.
> Attach the BSR presser foot.

- > Insert the plug for the cable vertically into the BSR connection (1) until you feel it click into place.



- > Switch the machine on.
 - The BSR display opens and the BSR 1 mode is activated.

Changing the Presser Foot

NOTICE

The Lens of the BSR Presser Foot is Dirty

The machine doesn't recognize the BSR presser foot.

- > Clean the lens with a soft, slightly damp cloth.

- > Raise the needle.
- > Raise the BSR foot.
- > Switch off the machine.
- > Remove the BSR foot from the machine.
- > Press both push buttons at the BSR foot against each other.

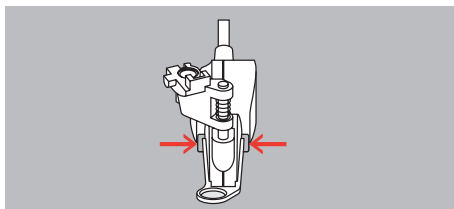

- > Pull the presser foot sole out of the guide downwards.
- > Insert the new presser foot sole into the guide and push upwards until it clicks into place.
- > Attach the BSR presser foot.

11.6 Using the BSR Mode

The BSR function can either be operated via the foot control or via the button «Start/Stop».

Start via the Foot Control: The foot control must be pressed down while quilting is in progress. The machine keeps running in BSR Mode 1 until the foot control is released, even if the fabric is not moved.

If quilting in BSR Mode 2 is stopped, the machine sews another stitch depending on the needle position and stops with needle position up.

Prerequisite:

- The slide-on table has been fitted.
- The knee lifter is attached.
- > Lower the feed dog.
- > Select the desired BSR Mode.

- > To lower the presser foot, push the button «Start/Stop» or press the foot control.
- > To start the BSR Mode, push the button «Start/Stop» again or press and hold the foot control again.
 - A red light is lit on the BSR Presser Foot.
- > Move the fabric to control the speed of the machine in the BSR Mode.
- > To stop the BSR Mode, push the button «Start/Stop» again or release the foot control.
 - The BSR Mode stops and the red light at the presser foot goes off.
- > To deactivate the BSR Mode and to quilt without automatic stitch lengths, tap «BSR Mode».

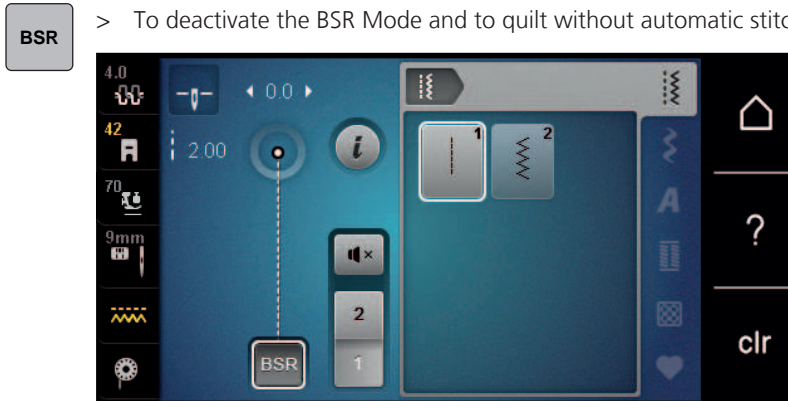

11.7 Securing Stitches

Securing in BSR1 Mode with the Button «Start/Stop»

Prerequisite:

- The BSR presser foot is fitted and connected to the machine.
- The BSR display opens and a BSR1 Mode is active.

- > Lower the feed dog.
- > Lower the presser foot.
- > Push the button «Needle position Up/Down» 2x.
 - The bobbin thread is brought up.
- > Hold the upper and the bobbin thread.
- > Push the button «Start/Stop».
 - Start the BSR Mode.
- > Sew 5 – 6 securing stitches.
- > Push the button «Start/Stop».
 - The BSR Mode stops.
- > Cut the thread.

Securing in BSR2 Mode

Prerequisite:

- The BSR presser foot is fitted and connected to the machine.
- The BSR display opens and a BSR2 Mode is active.

- > Lower the presser foot.
- > Tap «i-Dialog».
- > Tap «Securing Stitches».
- > Press the foot control or push the button «Start/Stop».

By moving the fabric some short securing stitches are sewn, then the programmed stitch length is activated and the securing function is deactivated automatically.

12 My BERNINA Embroidery

12.1 Overview Embroidery Module



- | | | | |
|---|--------------------------------|---|-----------------------------|
| 1 | Release Lever/Carrying Handle | 4 | Guide Rails for the Machine |
| 2 | Embroidery Arm | 5 | Connection to the Machine |
| 3 | Coupling for Securing the Hoop | | |

12.2 Supplied Accessories Embroidery Module

Overview Accessory Embroidery Module







Illustration	Name	Purpose
	Drop-shaped Embroidery Foot #26	For embroidering, darning and freehand quilting.
	Large Oval Embroidery Hoop	To embroider large embroidery designs or design combinations up to 145 x 255 mm (5.70 x 10.04 in). Including the template for precise fabric positioning.

Illustration	Name	Purpose
	Medium Embroidery Hoop	To embroider medium-sized embroidery designs up to 100 x 130 mm (3.94 x 5.12 in). Template for precise fabric positioning included.
	Embroidery Needle Assortment	For embroidering.
	Template Holder	To place and remove the template in or out of the embroidery hoop.
	Spool Net	For even thread unwinding with smooth threads from the thread spool, e.g. nylon, rayon, silk threads or metallic yarns.

12.3 Overview User Interface

Overview Functions/Visual Information

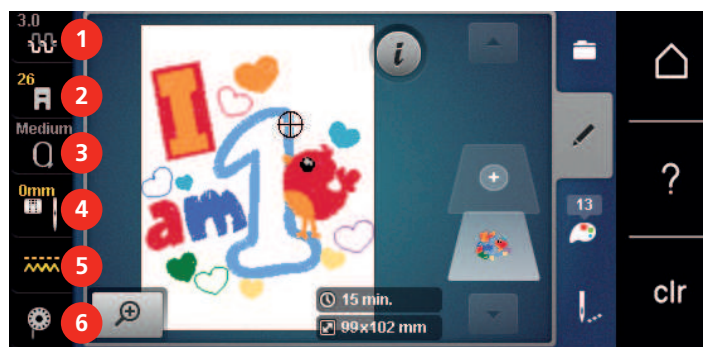

- | | |
|---|-----------------------------------|
| 1 «Upper Thread Tension» | 4 «Stitch Plate/Needle Selection» |
| 2 «Presser Foot Indicator/Presser Foot Selection» | 5 «Feed Dog Indicator» |
| 3 «Hoop Indicator/Select Hoop» | 6 «Bobbin Thread» |

Overview System Settings

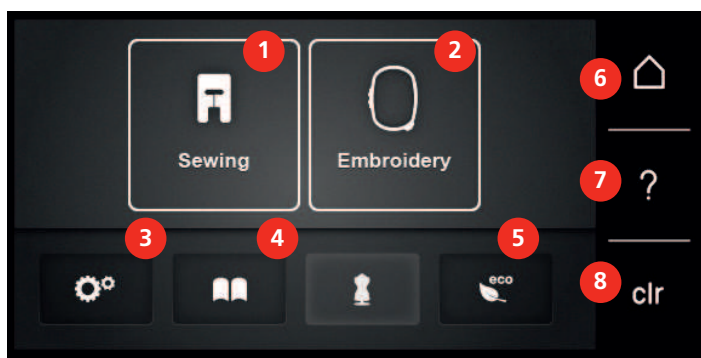

- | | | | |
|---|-------------------|---|------------------|
| 1 | «Sewing Mode» | 5 | «eco Mode» |
| 2 | «Embroidery Mode» | 6 | «Home» |
| 3 | «Setup Program» | 7 | «Help» |
| 4 | «Tutorial» | 8 | «Clear Settings» |

Overview Selection Menu Embroidery

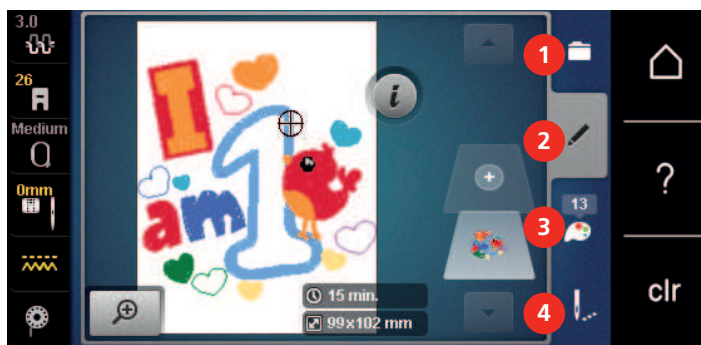

- | | | | |
|---|-------------|---|---------------------|
| 1 | «Selection» | 3 | «Color Information» |
| 2 | «Edit» | 4 | «Embroidery» |

12.4 Important Embroidery Information

Upper Thread

A good quality thread (name-brand manufacturer) is essential for embroidery so that the embroidery is not affected negatively because of poor thread or thread breakage.

Embroidery is particularly effective if you use 40wt glossy rayon or polyester embroidery threads as upper threads. They are available in a wide range of colors for beautiful embroidery.

- Polyester with a brilliant sheen is a hard-wearing, colorfast thread and has a high tensile strength which is suitable for all types of embroidery.
- Rayon is a soft viscose fiber with a brilliant sheen and suitable for fine, delicate embroidery, or items that will not receive excessive wear and tear.
- Metallic thread is a light to medium-weight thread suitable for special effects in embroidery.
- When working with metallic threads, the automatic bobbin thread cutter should be deactivated. The other thread cutters shouldn't be used either because the knives are likely to wear off very quickly.

- When using metallic threads, the speed and the upper thread tension should be reduced.



Bobbin Thread

In most cases black or white bobbin thread is used for embroidering. When both sides should have the same look, it is recommended to use the same color for bobbin and upper thread.

- Bobbin Fill is an especially soft and light polyester thread which is suited to be used as bobbin thread. This special bobbin thread ensures a steady thread tension and an optimal intertwining of the upper and bobbin thread.
- Darning and embroidery threads are fine mercerized cotton threads which are suitable for embroidery on cotton.



Selecting the Embroidery File Format

In order that embroidery designs can be read by the BERNINA Embroidery machine, they have to be created by the BERNINA Embroidery Software and exported as .EXP file. Besides the actual embroidery file, a .BMP file and an .INF file are generated additionally. The .BMP file allows a preview of the embroidery design and the .INF file provides the information on the thread colors. **Note:** If the .INF file is missing, the embroidery design cannot be displayed in the real color but only in standard colors. In this case, the colors can be entered manually in the color overview of the motif on the machine.

Additionally, following embroidery formats can be read by the machine: .PES, .PEC, .XXX, .PCS, .JEF and .DST. BERNINA International AG doesn't warrant that embroidery designs which have not been created or converted by the BERNINA Embroidery software can be correctly read and embroidered.

Embroidery Test

For the embroidery test, always use the original material reinforced with the same stabilizer as will be used later. For the embroidery test it is recommended to use the same colors, threads and needles which are planned to be used for the embroidery project.

The Size of the Embroidery Design

Embroidery designs can be enlarged or downsized on the embroidery machine or on the PC using the BERNINA Embroidery software (optional accessory). Scaling up/downsizing in a range of +/- 20 % provides the best results.

13 Embroidery Preparation

13.1 Attaching the Embroidery Module

Prerequisite:

- Extension table must not be fitted.
- > Make sure that the module and the machine are placed on a stable, even surface.
- > Ensure that the embroidery arm can move freely.
- > Carefully slide the embroidery module from left to right into the machine's embroidery module connection (1) and the guide rail (2).



13.2 Removing the Embroidery Module

- > Push the release lever (1) at the carrying handle of the embroidery module, keep it pressed and at the same time, move the embroidery module carefully to the left.



13.3 Preparing the Machine

Lower the Feed-dog

- > To lower the feed dog, push the button «Feed Dog Up/Down».



- > Fit the straight- and CutWork stitch plate (optional accessory).
- > Fit the needle.
- > Fit the embroidery foot.

Selecting the Embroidery Design

All of the embroidery designs can be either directly embroidered or can be changed using different functions offered by the embroidering machine. All the embroidery designs can be found at the end of this instruction manual. In addition to that, embroidery designs can be loaded from the personal memory or from the BERNINA USB stick (optional accessory).



> Tap «Home».



> Tap «Embroidery Mode».

> Select an alphabet, embroidery design or a personal embroidery design from one of the files.

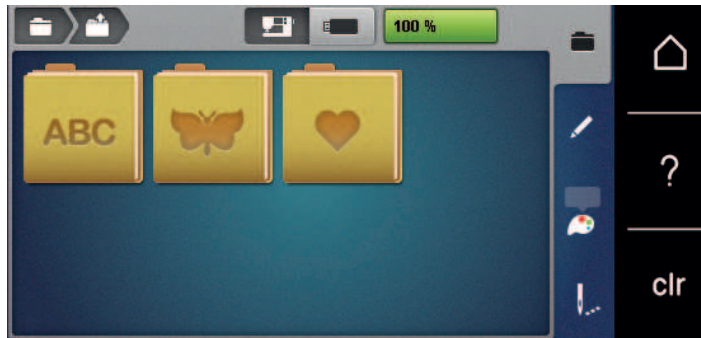

13.4 Embroidery Foot

Attaching the Embroidery Foot

- > Raise the needle.
- > Raise the presser foot.
- > Switch off the machine.
- > Push the clamping lever up (1).
- > Remove the presser foot (2).



- > Insert the embroidery foot from below into the bracket.
- > Press the clamping lever down.



Selecting the Stitch Plate in the User Interface

After having fitted the appropriate embroidery foot (Embroidery Foot #26, supplied accessory) it can be selected and saved on the machine. Moreover optional presser feet can be displayed which are available for the currently selected embroidery design.

- > Switch the machine on.
- > Select the embroidery design.
- > Tap «Presser Foot Indicator/Presser Foot Selection».
- > Select the fitted embroidery foot.



13.5 Needle and Stitch Plate

Inserting the Embroidery Needle



Embroidery needles of the type 130/705 H-SUK provide a larger eye and are slightly rounded. This avoids thread abrasion when using Rayon- and cotton embroidery thread. Depending on the embroidery thread use a size No. 70-SUK to No. 90-SUK needle.

- > Raise the needle.
- > Switch off the machine.
- > Remove the fitted foot.
- > Loosen the fixing screw for the needle by hand.



- > Pull the needle down.
- > Hold the new needle with the flat side to the back.
- > Insert the needle as far as it will go.
- > Tighten the fixing screw by hand.

Selecting the Embroidery Needle in the User Interface

After changing the needle, you can check whether this can be used with the selected stitch plate.



- > Tap «Stitch Plate/Needle Selection».

> Select the fitted needle.



- If the selected needle is suitable in combination with the stitch plate, embroidering can be started.
- If the selected needle is not suitable in combination with the stitch plate, starting the machine is automatically blocked.

Selecting Needle Type and Needle Size

Useful reminder function: So that no information is lost, the needle type and needle thickness can also be saved on the machine. This means that the saved needle type and needle thickness can be checked at any time.



> Tap «Stitch Plate/Needle Selection».



> Tap «Needle Information».

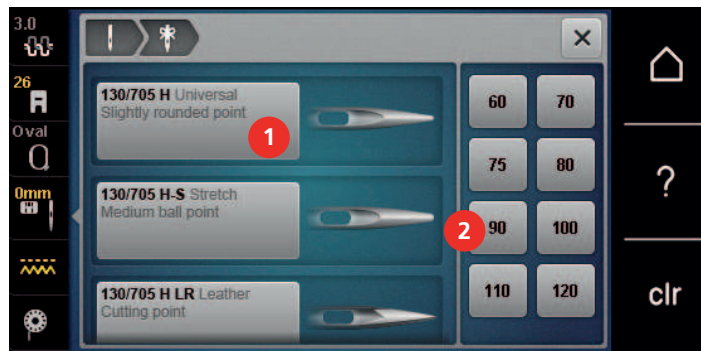

- > Select the needle type (1) of the fitted needle.
- > Select the needle type (2) of the fitted needle.

Adjusting the Needle Position Up/Down



- > To bring the thread up, push the button «Needle position Up/Down».
 - The needle is lowered and raised once.

Attaching the Stitch Plate

The stitch plate (Straight and CutWork Stitch Plate) has a small hole in the needle area. The stitch formation (thread knotting of upper and bobbin thread) is thus optimized. This results in a more beautiful stitch appearance.

- > To lower the feed dog, push the button «Feed Dog Up/Down».



- > Switch off the machine.
- > Remove the needle.
- > Remove the presser foot.
- > At the marking on the upper right corner of the stitch plate, push the stitch plate downwards until it tips.



- > Remove the stitch plate.
- > Place the opening of the stitch plate (Straight and CutWork Stitch Plate) above the corresponding guide pins and press it down until it clicks into place.

Selecting the Stitch Plate in the User Interface

After changing the stitch plate, you can check whether it can be used with the selected needle.



- > Tap «Stitch Plate/Needle Selection».
- > Select Straight and CutWork Stitch Plate.



Thread-up Command

The machine must be ready for embroidery to bring up the bobbin thread. The bobbin thread can be brought up in one step for a manual knotting. If no securing stitches are wanted, it is recommended to deactivate the securing stitches in the Setup.



- > Hold the upper thread.
- > Push the button «Presser Foot Up/Down».
 - The bobbin thread is brought up automatically.

13.6 Embroidery Hoops

Overview Embroidery Hoop Selection

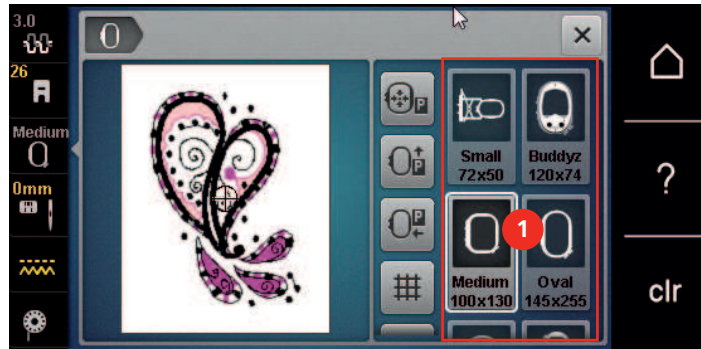

1 Hoop Selection

Selecting the Embroidery Hoop

The best embroidery result is achieved when the smallest possible embroidery hoop for the embroidery design is selected.

The embroidery design has a pre-set size which is displayed.

Prerequisite:

- The embroidery design is selected.



- > Tap «Hoop Indicator/Select Hoop».
 - The machine selects the optimal embroidery hoop according to the size of the embroidery design automatically. If the preset embroidery hoop is not available, another desired embroidery hoop can be selected. When an embroidery hoop is attached which does not correspond with the selected one, the attached hoop is considered active and the embroidery design area is displayed accordingly.
- > Select the desired embroidery hoop.

Tear-away Stabilizers

Using a stabilizer ensure more stability of the embroidery project. A tear-away stabilizer suits all woven and non-stretch materials. 1 – 2 layers can be used. Stabilizers are available in different weights. With larger areas to be embroidered the stabilizer will remain under the embroidery thread. The stabilizer is applied to the wrong side of the fabric with temporary adhesive spray. Carefully cut away excess stabilizer after embroidering.

Cut-away Stabilizers

Using a stabilizer ensure more stability of the embroidery project. A cut-away stabilizer suits all elastic materials. 1 – 2 layers can be used. Stabilizers are available in different weights. With larger areas to be embroidered the stabilizer will remain under the embroidery thread. The stabilizer is applied to the wrong side of the fabric with temporary adhesive spray. Carefully cut away excess stabilizer after embroidering.

Using Adhesive Spray

The application of spray adhesive is recommended for stretch and smooth materials and knitware. It prevents the fabric from losing shape and slipping. Appliqués can be exactly positioned with spray adhesive. The spray adhesive shouldn't be used near the machine to avoid contamination.

- > Use the spray adhesive carefully at a distance 25 – 30 cm (9 – 12 inch) when spraying the stabilizer.
- > Adhere the sprayed stabilizer to the wrong side of the fabric carefully, smoothing material so there are no puckers.
- > Position smaller parts such as pocket flaps or collars on the stabilizer.
- > To avoid the possibility of getting hoop marks when working with napped materials or fleece, don't hoop the parts but spray the stabilizer and hoop it.

- > Adhere the fabric to be embroidered.
- > Remove any adhesive residue before starting the machine.

Using Spray Starch

Spray starch is ideal for additional stiffening fine, loosely woven materials. Always use an additional stabilizer on the wrong side of the material.

- > Spray the area to be embroidered.
- > Let it dry or press gently with a warm iron if necessary.

Using Iron-on Interfacing

Iron-on interfacings are available in a variety of weights. It is recommended to use an iron-on interfacing which is easily removable from the basic fabric. An Iron-on interfacing suits all materials that are easily distorted like stretch fabric such as tricot and jersey.

- > Iron-on interfacings are ironed to the wrong side of the material using a warm iron.

Using Paper-backed Adhesive Stabilizer

Paper-backed adhesive stabilizers are intended to be used for fabrics such as jersey and silk as well as for embroidery projects which are not suited to be hooped in the embroidery hoop.

- > Place the stabilizer in the hoop, so that the paper side is up.
- > Use a pair of scissors to score the paper and remove paper in the hoop area.
- > Position the fabric to be embroidered on the stabilizer and press it on place.
- > Remove any adhesive residue before starting the machine.

Using Water-soluble Stabilizer



For lace embroidery it is recommended to hoop 1 - 3 layers of water-soluble stabilizer in the embroidery hoop. As the embroidery design is not embroidered on the fabric, only the thread embroidered design is left. The embroidery designs should be combined with short stitches otherwise the individual designs may fall out.

Water-soluble stabilizers are ideal for fine, sheer fabrics where other stabilizers may show through the embroidery stitches as well as for lace embroidery. The stabilizer dissolves in water. Water-soluble stabilizers are an ideal protection for looped pile fabrics preventing the loops from being damaged. It prevents threads from sinking into the material and keeps the fabric pile from poking through the embroidery.

- > Place the stabilizer on the underside of the material.
- > Use adhesive spray to adhere stabilizer if necessary.
- > For material with a pile, reinforce with additional, suitable stabilizer on the wrong side.
- > Place all the layers together into the embroidery hoop.
- > After dissolving, lay the motif down flat and let dry.

Preparing the Embroidery Hoop

The embroidery hoop consists of an outer and an inner hoop. There is a corresponding template for every hoop. The area to be embroidered is marked in 1 cm (0.39 inch) squares. The center and corner points are marked with holes. The required marks can be transferred to the material.

- > Mark the center of an embroidery design on the fabric, using a water-soluble pen.

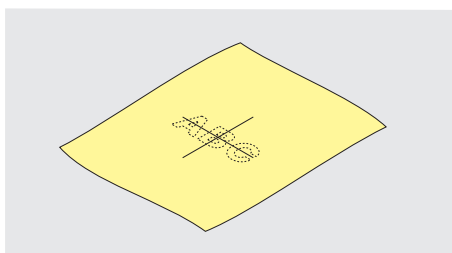

- > Loosen the screw on the outer hoop.

- > Remove the inner hoop.
- > Make sure that the arrows marks of both hoops match.
- > Attach the template holder.
- > Place the template in the inner hoop, so the BERNINA logo is at the front edge at the arrow mark until it clicks into place.

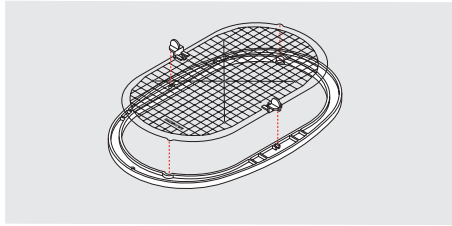

- > Place the fabric under the inner hoop.
- > Line up the marked center point on the center of the template.
- > Place the material and the inner hoop on the outer hoop, so that the arrow markings of both hoops are aligned.

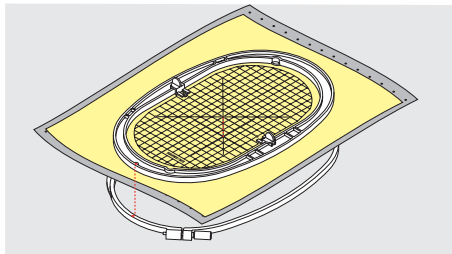

- > Fit the hoops into each other so that the material does not move.
- > Hoop the fabric tautly in the embroidery hoop.
- > Tighten the screw.
- > Remove the template from the hoop by using the template holder.
- > To avoid scratches on the free arm, press the inner hoop into the outer hoop so that the inner hoop including the fabric protrudes downwards by up to 1 mm.

Attaching the Hoop

- > Raise the needle.
- > Raise the embroidery foot.
- > Hold the hoop with the right side of the fabric up with the attaching mechanism to the left.
- > Position the hoop below the embroidery foot.
- > Press both attaching mechanisms (1) of the hoop towards each other.
- > Position the embroidery hoop (2) above the bracket of the embroidery arm.
- > Press the hoop down until it clicks in position.
- > Release the attaching mechanism (1).

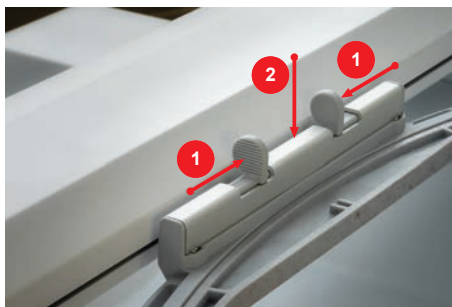

- > Press the attaching mechanisms of the hoop towards each other to remove the hoop.
- > Remove the hoop.

Overview Embroidery Functions



- | | | | |
|---|--|---|---|
| 1 | «Center the Needle to the Embroidery Hoop» | 4 | «Grid On/Off» |
| 2 | «Move Hoop to the Back» | 5 | «Center of Embroidery Design» |
| 3 | «Move Hoop to the Left» | 6 | «Virtual Positioning»
(becomes visible by scrolling) |

Centering the Needle to the Embroidery Hoop

Relocating the embroidery hoop facilitates threading when the needle is close to the embroidery hoop.



- > Tap «Hoop Indicator/Select Hoop».



- > Tap «Center the Needle to the Embroidery Hoop».
- > Thread the upper thread.



- > To move the hoop back to its previous position, push the button «Start/Stop».

Move Hoop to the Back

To facilitate changing the bobbin, it is recommended to move the hoop to the back before threading. This makes it easier to open the bobbin cover.



- > Tap «Hoop Indicator/Select Hoop».



- > Tap «Move Hoop to the Back».
- > Thread the bobbin thread. (see page 45)



- > To move the hoop back to its previous position, push the button «Start/Stop». If necessary, pull back the upper thread.

Moving the Module for the Sewing Mode

The embroidery module can be positioned so that any sewing projects can be carried out even if the module is connected.



- > Tap «Hoop Indicator/Select Hoop».
- > Remove the hoop.



- > Tap «Move Hoop to the Left».



- > Tap «Home».



- > Tap «Sewing Mode».

Grid On/Off

When the center of the hoop and the grid are displayed, the embroidery design can be positioned more exactly.



> Tap «Hoop Indicator/Select Hoop».



> To show the hoop center on the display, tap «Grid On/Off».

> To show the grid lines, tap «Grid On/Off» again.

> To hide the hoop center and the grid lines, tap «Grid On/Off» again.

Locating the Center of the Embroidery Design

The embroidery hoop is positioned so that the needle is exactly above the center of the embroidery design or the motif begin.



> Tap «Hoop Indicator/Select Hoop».



> To position the hoop so that the needle is placed exactly over the center of the embroidery design, tap «Center of Embroidery Design».

> To position the hoop so that the needle is placed exactly over the motif start, tap «Center of Embroidery Design» again.

Virtual Positioning of the Embroidery Hoop

The embroidery hoop is automatically moved to the new position as soon as the embroidery design is repositioned. Therefore, the icon «Virtual Positioning» is activated automatically and outlined in yellow when an embroidery hoop is attached.

Prerequisite:

- The hoop is attached.



> Tap «Hoop Indicator/Select Hoop».



> To deactivate the automatic movement of the hoop after repositioning the embroidery design, tap «Virtual Positioning».

- The «Virtual Positioning» is not yellow-outlined.

> To activate the automatic movement of the hoop after repositioning the embroidery design, tap «Virtual Positioning» again.

14 Setup Program

14.1 Adjusting the Embroidery Settings in the Setup Program

Further information about this topic (see page 51).

15 Creative Embroidering

15.1 Overview Embroidering

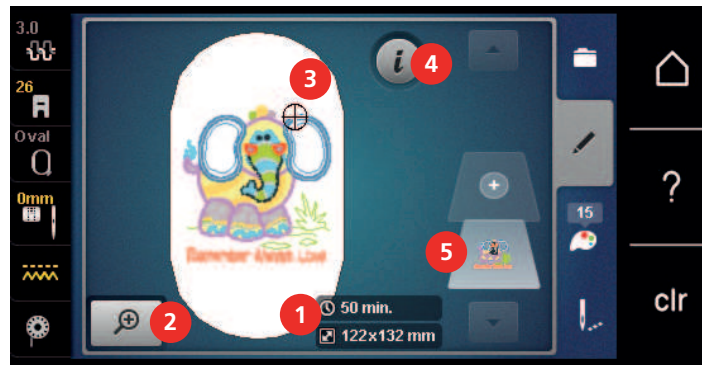

- | | | | |
|---|--|---|--------------------------|
| 1 | Embroidery Time/Embroidery Design Size | 4 | «i-Dialog» |
| 2 | Scaling Up, Downsizing and Moving the Embroidery Design View | 5 | Embroidery design Layers |
| 3 | Area to be Embroidered | | |

15.2 Selecting and Changing the Embroidery Design



- > Tap «Selection».



- > Tap «Loading the Embroidery Design».
- > Select a new embroidery design.

15.3 Checking the Embroidery Time and the Embroidery Design Size

In the display «Editing» at lower right (1), the estimated embroidery time is indicated in minutes and the width and height of the embroidery design is indicated in millimeters.

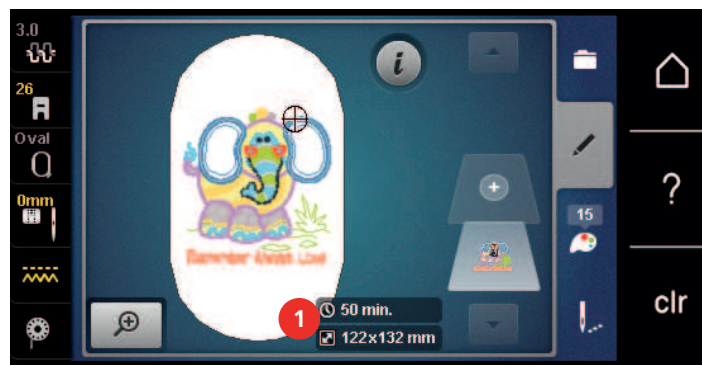

15.4 Regulating the Speed

The sewing speed can be adjusted infinitely variable with the slide.

- > Move the slide to the left to reduce the sewing speed.
- > Move the slide to the right to increase the sewing speed.

15.5 Editing the Embroidery Design

Overview Editing Embroidery Design

- > To edit an embroidery design, select the embroidery design.



> Tap «i-Dialog».

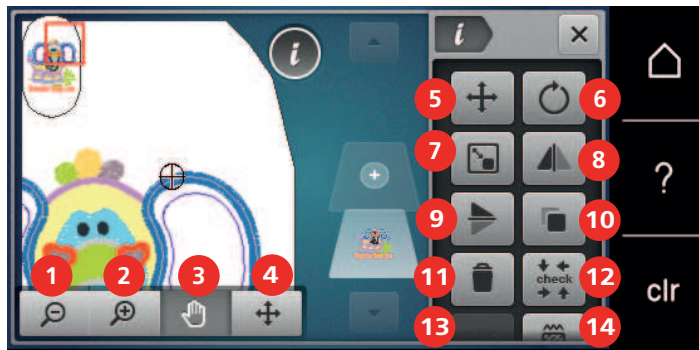

- | | | | |
|---|--------------------------------|----|---|
| 1 | «Zoom Out» | 8 | «Mirror Image Left/Right» |
| 2 | «Zoom In» | 9 | «Mirror Image Up/Down» |
| 3 | «Move View» | 10 | «Duplicate» |
| 4 | «Relocating a Stitch Pattern» | 11 | «Deleting» |
| 5 | «Relocating a Stitch Pattern» | 12 | «Check Embroidery Design Size» |
| 6 | «Rotate the Embroidery Design» | 13 | «Word Art»
(only with selected alphabet) |
| 7 | «Change Design Size» | 14 | «Alter Stitch Type/Stitch Density» |

Scaling Up the Embroidery Design View

The view of the embroidery design can be scaled up. In addition to that, the view can be adjusted with or without changing the embroidery position.

> Select the embroidery design.



> To edit the view of the embroidery design, tap «Zoom In».



> To scale up the view of the embroidery design, tap «Zoom In» 1 up to 4 times.



> To get back to the Edit Mode, tap «Zoom Out» 1 up to 4 times.

Downsizing the Embroidery Design

The view of the embroidery design can be downsized. In addition to that, the view can be adjusted with or without changing the embroidery position.

> Select the embroidery design.



> To edit the view of the embroidery design, tap «Zoom In».



> To downsize the view of the enlarged embroidery design gradually, tap «Zoom Out» 1 – 4 times.

Moving the Embroidery Design View

The view of the embroidery design can be moved. In addition to that, the view can be adjusted with or without changing the embroidery position.

> Select the embroidery design.



> To activate «Move View», tap «Zoom In».



– «Move View» is activated (dark gray).

> Move the view of the embroidery design.



– The embroidery position is not altered.





> To get back to the Edit Mode, tap «Zoom Out».

Moving the Embroidery Design in Enlarged View

In addition to that, the view can be adjusted with or without changing the embroidery position. In addition to that, the view can be adjusted with or without changing the embroidery position.

- > Select the embroidery design.
-  > To display the icon «Relocating a Stitch Pattern», tap «Zoom In».
-  > Tap «Move the Embroidery Design».
 - The icon turns dark gray.
- > Move the view of the embroidery design.
 - The embroidery position is altered.
-  > To get back to the Edit Mode, tap «Zoom Out».



Moving the Embroidery Design

- > Select the embroidery design.
-  > Tap «i-Dialog».
-  > Tap «Move the Embroidery Design».
 - > Turn the «Upper Multi-function Knob» to move the embroidery design horizontally in 1/10-mm steps.
 - > Turn the «Lower Multi-function Knob» to move the embroidery design vertically in 1/10 mm steps or tap and hold the embroidery design to move the embroidery design as you like.
 - The relocation is indicated in the yellow-outlined icons.



-  > Tap «Center of Embroidery Design».
 - The embroidery design is repositioned in the center of the embroidery hoop.

Rotating the Embroidery Design

- > Select the embroidery design.
-  > Tap «i-Dialog».
-  > Tap «Rotate the Embroidery Design».
 - > Turn the «Upper Multi-function Knob» or the «Lower Multi-function Knob» to the right to rotate the embroidery design clockwise.
 - > Turn the «Upper Multi-function Knob» or the «Lower Multi-function Knob» to the left to rotate the embroidery design counter-clockwise.
-  > To rotate the embroidery design in 90°-steps, tap «Rotate the Embroidery Design +90°».

Altering the Embroidery Design Size Proportionally



Enlargements or reductions of the motif size up to maximum 20 % achieve the best results.

If the motif size is to be altered by more than 20 %, the motif should be adapted in a separate embroidery software and then reloaded onto the machine.

- > Select the embroidery design.
- > Tap «i-Dialog».



- > Tap «Change Design Size».



- > If «Retain Proportions» is not outlined in white, tap «Retain Proportions».
 - «Retain Proportions» is outlined in white.



- > Turn the «Upper/Lower Multi-function Knob» to the right to scale up the embroidery design proportionally.
- > Turn the «Upper/Lower Multi-function Knob» to the left to downsize the embroidery design proportionally.

Altering the Embroidery Design Size Disproportionally



Enlargements or reductions of the motif size up to maximum 20 % achieve the best results.

If the motif size is to be altered by more than 20 %, the motif should be adapted in a separate embroidery software and then reloaded onto the machine.

- > Select the embroidery design.
- > Tap «i-Dialog».



- > Tap «Change Design Size».



- > If «Retain Proportions» is outlined in white, tap «Retain Proportions».
 - «Retain Proportions» is not outlined in white.



- > To make the embroidery design wider, turn the «Upper Multi-function Knob» clockwise.
- > To make the embroidery design narrower, turn the «Upper Multi-function Knob» anti-clockwise.
- > To make the embroidery design longer, turn the «Lower Multi-function Knob» clockwise.
- > To make the embroidery design shorter, turn the «Lower Multi-function Knob» anti-clockwise.

Mirroring Embroidery Designs

Embroidery designs can be mirror-imaged both vertically and horizontally.

- > Select the embroidery design.
- > Tap «i-Dialog».



- > To mirror the embroidery design horizontally, tap «Mirror Image Left/Right».



- > To mirror the embroidery design vertically, tap «Mirror Image Up/Down».

Changing the Stitch Type

If the satin stitches are too long, they can be changed to step stitches.

- > Select the Embroidery Design.
- > Tap «i-Dialog».



- > Tap «Alter Stitch Type/Stitch Density».



- > Touch the switch in the upper section of the display (1) to change the satin stitch to the step stitch.
- > Set and confirm the stitch length 2.

Altering the Stitch Density

If the satin stitches are embroidered too densely, the stitch density can be adjusted.

- > Select the embroidery design.
- > Tap «i-Dialog».



- > Tap «Alter Stitch Type/Stitch Density».



- > Adjust the stitch density (1).

Checking the Size and the Position of the Embroidery Design

It can be checked whether or not the embroidery design matches the designated position/location on the fabric. Points which are beyond the embroidery hoop are not traveled to.

- > Select the embroidery design.
- > Tap «i-Dialog».



- > Tap «Check Embroidery Design Size».
 - The embroidery hoop travels all the way until the needle is at the position as it is indicated in the display.

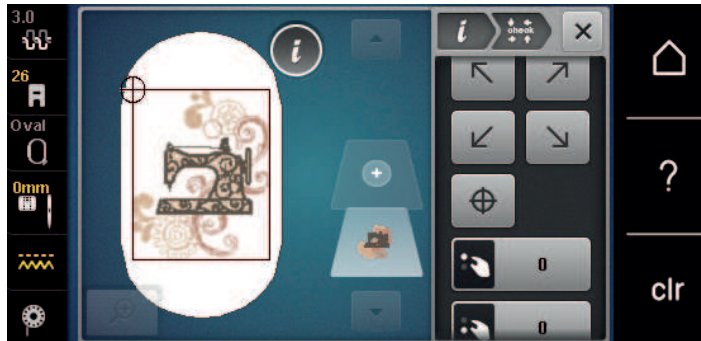

- > To select the desired corner of the embroidery design, tap the respective arrow.
 - The embroidery hoop travels all the way until the needle is at the position as it is indicated in the display. If the embroidery design hasn't been positioned correctly yet, the position can be altered via the «Upper/Lower Multi-function knobs» and the complete embroidery positions can be checked again.



- > To position the needle in the center of the embroidery design, tap «Center of Embroidery Design».
- > Turn the «Upper Multi-function Knob» to move the embroidery design horizontally.
- > Turn the «Lower Multi-function Knob» to move the embroidery design vertically.

Duplicating the Embroidery Design

- > Select the embroidery design.
- > Tap «i-Dialog».



- > Tap «Duplicate».
 - The embroidery design (1) is duplicated (2).

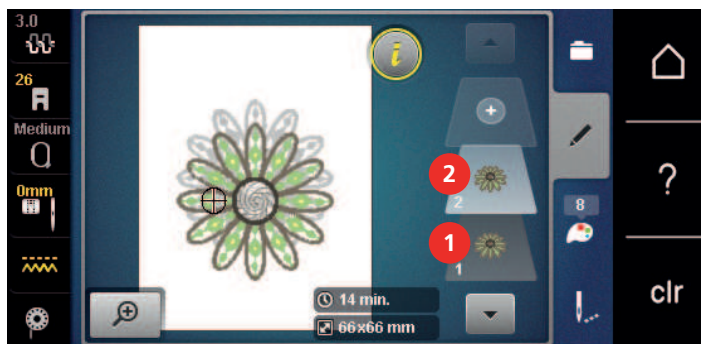

Deleting an Embroidery Design

The active embroidery design is deleted.

- > Select the embroidery design.
- > Tap «i-Dialog».



- > Tap «Deleting».

15.6 Combining Embroidery Designs

Combining Embroidery Designs

In the Combi-mode several embroidery designs can be combined.

- > Select the embroidery design.
- > Tap «Adding an Embroidery Design».

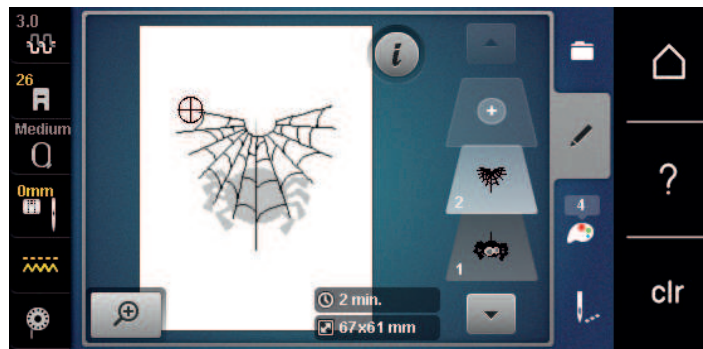

- > Select another embroidery design.

Deleting a Single Embroidery Design

Prerequisite:

- A combination of embroidery designs has been created.
- > Tap the desired embroidery design in the area of the embroidery design level (1), keep it touched and drag it outwards.
 - A new window opens.

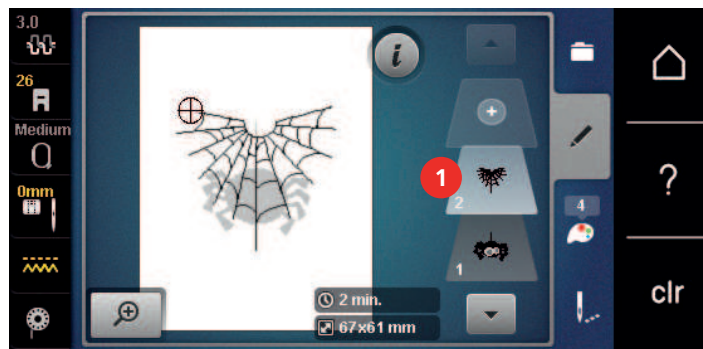

- > To delete the selected embroidery design, tap «Confirm».

Duplicating a Combination

When a combination is duplicated, the individual embroidery designs cannot be selected anymore.

- > Select the embroidery design.
- > Tap «Adding an Embroidery Design».
- > Select another embroidery design.



> Select the combination (1).



> Tap «i-Dialog».



> Tap «Duplicate».

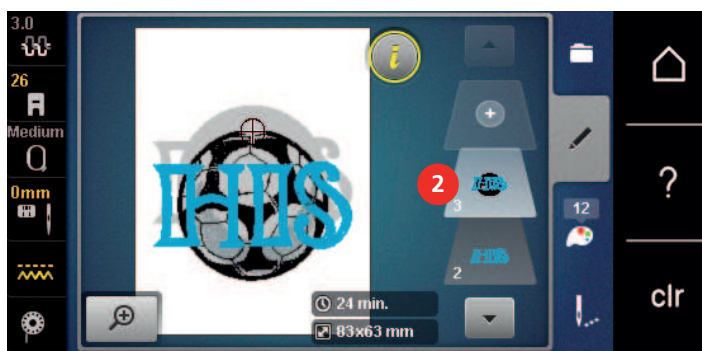

– The combination is duplicated (2).

15.7 Creating Lettering

Overview Embroidery Alphabets

Embroidery Design	Name
ABC	Swiss Block
<i>ABC</i>	Anniversary
ABC	Quilt Block
ABC	Childs Play
АБВ	Russian Textbook
<i>ABC</i>	Curly
ABC	Rounded Sans

Creating Lettering



- | | | | |
|---|-------------------------|---|---------------------------------------|
| 1 | Entry Field | 5 | «Numbers and Mathematical Characters» |
| 2 | «Deleting» | 6 | «Special Characters» |
| 3 | «Upper Case Characters» | 7 | «Cancel» |
| 4 | «Lower Case Characters» | 8 | «Confirm» |



A lettering is always embroidered in one color. To embroider single letters or single words in another color, every letter or every word has to be selected individually and placed in the area to be embroidered.

Lettering can be positioned within the hoop as you like. When the embroidery design is positioned outside the area to be embroidered, the hoop is outlined in red on the display. By means of the hoop selection it is possible to check whether or not the embroidery design can be embroidered in another hoop. If a lettering does not fit into one hoop, individual words can be combined and positioned one below one another, for example.



- > Select «Alphabets».
- > Select an alphabet.
- > Enter and confirm the text.

Editing the Lettering



- > A lettering has been created.
- > Tap «i-Dialog».



- > Tap «Word Art».
- > To change the distance between the characters in increments of one millimeter, turn the «Upper Multi-function Knob».
- > Turn the «Lower Multi-function Knob» to the left or right to curve the writing upwards or downwards.

15.8 Changing the Colors of the Embroidery Design

Overview Changing the Color

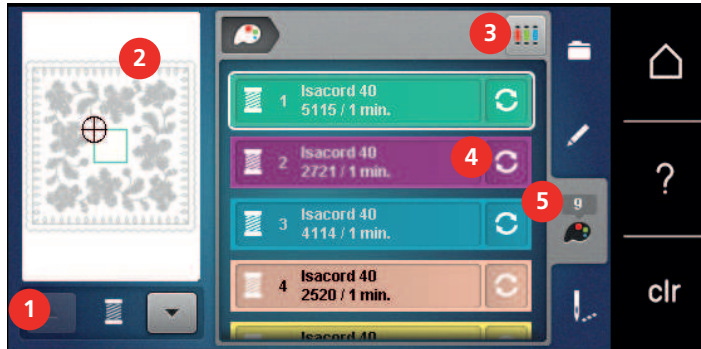

- | | | | |
|---|----------------------------|---|------------------------|
| 1 | «Color Indication» | 4 | «Altering Color/Brand» |
| 2 | Preview for Selected Color | 5 | «Color Information» |
| 3 | «Assign Thread Brand» | | |

Changing the Colors

- > Select the embroidery design.
- > Tap «Color Information».



- > To change a color, tap «Altering Color/Brand» next to the color to be changed.
- > To display additional colors, swipe up or down on the display.



- > To select the color by entering the color number, tap «Color Selection via Number».
- > Enter the number for the required color.
 - The color icon is displayed on the left.
- > To confirm the color selection, touch the color icon that is displayed on the left.

Changing the Thread Brand

- > Select the embroidery design.
- > Tap «Color Information».



- > Tap «Altering Color/Brand».
- > To display other thread brands, scroll to the left and to the right.



- > Tap «Assign Thread Brand».
- Any thread colors of the selected embroidery design will be matched with the selected thread brand.

15.9 Embroidering the Embroidery Design

Overview Embroidery Menu

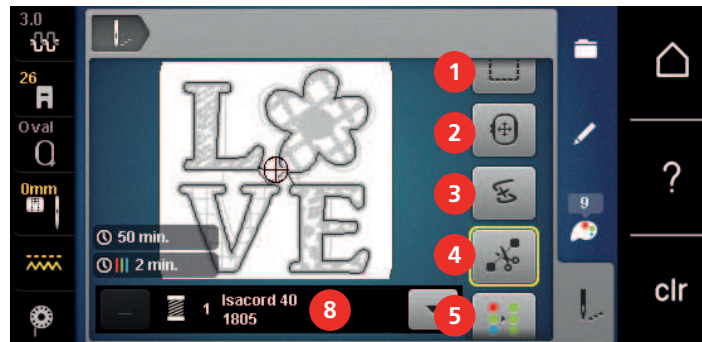

- | | | | |
|---|-------------------------------|---|---|
| 1 | «Basting» | 5 | «Multi-colored Embroidery Design On/Off» |
| 2 | «Move the Hoop» | 6 | «Increasing the Embroidery Speed»
(becomes visible by scrolling) |
| 3 | «Embroidery Sequence Control» | 7 | «Reduce Color Changes»
(becomes visible by scrolling) |
| 4 | «Cut Connecting Stitches» | 8 | «Color Indication» |

Adding Basting Stitches

The basting stitches can be embroidered along the embroidery design. As a result, the fabric and the stabilizer are better fixed together.

- > Select the embroidery design.
- > Tap «Embroidery».



- > To embroider the basting stitches along an embroidery design, tap «Basting».
- > To embroider the basting stitches along the hoop, tap «Basting» again.
- > To deactivate the basting stitches, tap «Basting» again.



Moving the Hoop

If the embroidery design is so big that repeated rehooping is necessary, the embroidered design can be moved again.

- > Select the embroidery design.
- > Tap «Embroidery».



- > Tap «Move the Hoop».
- > Turn the «Upper Multi-function Knob» to move the embroidery design horizontally.
- > Turn the «Lower Multi-function Knob» to move the embroidery design vertically.



- > To accept the settings, tap «Embroidery» in the Process Navigation.



Embroidery Sequence Control when the Thread Breaks

If the thread breaks, the needle can be repositioned in the embroidery design using the function Embroidery Sequence Control.

- > Select the embroidery design.
- > Tap «Embroidery».





- > Tap «Embroidery Sequence Control».
 - A compact view of the embroidery design appears on the left side of the display. On the right side the embroidery design is shown in enlarged view.
- > Select the desired position in the compact view.
- > Turn the «Upper Multi-function Knob» to move the hoop stitch by stitch.
- > Turn the «Lower Multi-function Knob» to move the hoop in large steps.
 - The number in the yellow-outlined icon indicates the number of stitches within the embroidery sequence.



- > To select the desired stitch by entry, tap the icon «Stitch Position via Number».

Cutting Connecting Stitches

The function is activated as standard and the connection stitches are automatically cut. If the function is deactivated, the connection stitches must be cut by hand.



- > Select the embroidery design.
- > Tap «Embroidery».



- > To switch off the function, tap «Cut Connecting Stitches».
- > To switch on the function, tap «Cut Connecting Stitches» again.

Reducing Color Changes

When the embroidery designs overlap, the color changes **cannot** be reduced.



- > Select the embroidery design.
- > Tap «Embroidery».



- > Tap «Reduce Color Changes».
 - Identical colors of the embroidery design are collected to one color.

Multi-colored Embroidery Design On/Off

Multi-colored embroidery designs can also be embroidered in one color.



- > Select the embroidery design.
- > Tap «Embroidery».



- > Tap «Multi-colored Embroidery Design On/Off».
 - The embroidery design is embroidered in one color.

Color Indication

Every color of the embroidery design can be selected individually. The hoop moves to the first stitch of the current color. The currently active color can be embroidered individually or in another sequence.



- > Select the embroidery design.
- > Tap «Embroidery».
- > Touch the icon Scroll up to select the previous color of the embroidery design.

15.10 Freearm Embroidery

Free arm embroidering is defined as embroidering tubular fabrics or garments which are positioned around the free arm of the embroidery machine while being embroidered. Often used with sleeves, pant legs or other narrow-tailored garments.



A fabric tube can be conveniently placed around the freearm of the machine if the embroidery hoop is moved to the left into the park position before attaching or removing it. To return the hoop to the embroidery position afterwards, push the button «Start/Stop».

If possible, use a full bobbin as the embroidery hoop must be removed when the bobbin is changed.

The movability of the embroidery arm can be limited or impeded with very narrow tubes. Therefore please make sure that the embroidery hoop can move forwards and backwards sufficiently. An impediment of the embroidery arm caused by a tube which is too tight can result in embroidery design offset or in damaging the fabric.

Check the Movability of the Freearm

Please note: With tiny fabric tubes, deactivate the thread-away in the Setup Program if necessary.

- > Open the embroidery design on the machine and edit as desired.
- > Mark the embroidery design position and the size on the fabric in a suitable way.
- > Select the embroidery hoop as small as possible.
- > Hoop or stick the fabric along with the appropriate stabilizer in the embroidery hoop, depending on the stabilizer.
- > Pull the fabric tube carefully over the freearm of the machine and attach the embroidery hoop at the clutch of the embroidery module.
- > If necessary, reposition the embroidery design.
- > Tap «Check Embroidery Design Size».
- > After the successful check of the embroidery design size, start the embroidery process.
 - Detailed instructions about embroidery, the use of suitable materials or selecting the required embroidery settings of the machine can be found in the “Tutorial” under embroidery techniques --> Embroidering.



15.11 Administering Embroidery Designs

Administering Embroidery Designs

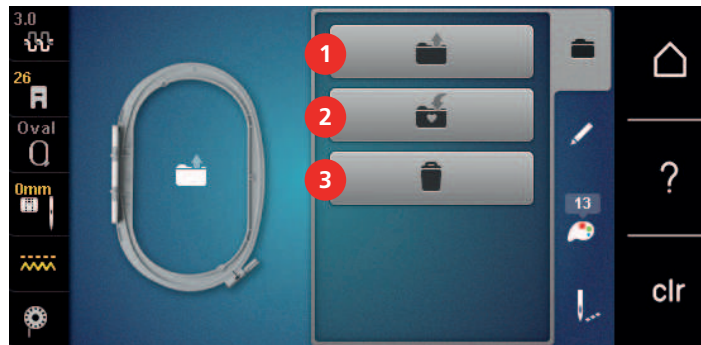



- | | | | |
|---|---------------------------------|---|-------------------------------|
| 1 | «Loading the Embroidery Design» | 3 | «Delete an Embroidery Design» |
| 2 | «Save Embroidery Design» | | |

Saving Embroidery Designs in the Personal Memory





In the file «Save Embroidery Designs» any embroidery designs including individually edited embroidery designs can be saved.

- > Select the embroidery design.
- > Edit the embroidery design.
- > Tap «Selection».







-  > Tap «Save Embroidery Design».
 - The embroidery design to be saved is outlined in yellow.
-  – The «Embroidery Machine» is activated.
-  > Tap «Confirm».





Saving the Embroidery Design on the BERNINA USB Stick

- > Select the embroidery design.
- > Edit the embroidery design.
-  > Tap «Selection».
-  > Tap «Save Embroidery Design».
 - The embroidery design to be saved is outlined in yellow.
- > Insert the BERNINA USB stick into the USB port of the machine.
-  > Tap «USB Stick».
-  > Tap «Confirm».

Overwriting the Embroidery Design in the Personal Memory



- > Select the embroidery design.
- > Edit the embroidery design.
-  > Tap «Selection».
-  > Tap «Save Embroidery Design».
 - The embroidery design to be saved is outlined in yellow.
-  – The «Embroidery Machine» is activated.
- > Select the embroidery design which is to be overwritten.
-  > Tap «Confirm».





Overwriting the Embroidery Design on the BERNINA USB Stick

- > Select the embroidery design.
- > Edit the embroidery design.
-  > Tap «Selection».
-  > Tap «Save Embroidery Design».
 - The embroidery design to be saved is outlined in yellow.
- > Insert the BERNINA USB stick into the USB port of the machine.
-  > Tap «USB Stick».
- > Select the embroidery design which is to be overwritten.
-  > Tap «Confirm».





Importing Stitch Patterns

Stitch patterns or stitch pattern combinations can be imported from sewing mode into embroidery mode and edited like embroidery designs. For example, border designs can be quickly and easily created and saved as embroidery designs in the folder «Personal embroidery designs».





-  > Tap «Home».
-  > Tap «Sewing Mode».
- > Select the stitch pattern.

-  > Tap «Home».
-  > Tap «Embroidery Mode».
 - The stitch pattern is automatically stored in the folder «Personal Embroidery Design».
-  > Select «Personal Embroidery Design».
-  > Select the stitch pattern.

Loading an Embroidery Design from the Personal Memory





-  > Tap «Selection».
-  > Tap «Loading the Embroidery Design».
-  > Select «Personal Embroidery Design».
-  > Select the embroidery design.

Loading an Embroidery Design from the BERNINA USB Stick







-  > Tap «Selection».
-  > Insert the BERNINA USB stick into the USB port of the machine.
-  > Tap «USB Stick».
-  > Select a personal embroidery design.

Deleting an Embroidery Design from the Personal Memory

The embroidery designs which are saved in the personal memory can be deleted individually.

-  > Tap «Selection».
-  > Tap «Deleting».
-  – The «Embroidery Machine» is activated.
-  > Select the embroidery design which is to be deleted.
-  > Tap «Confirm».

Deleting an Embroidery Design from the BERNINA USB Stick

-  > Tap «Selection».
-  > Tap «Deleting».
-  > Insert the BERNINA USB stick into the USB port of the machine.
-  > Tap «USB Stick».
-  > Select the embroidery design which is to be deleted.
-  > Tap «Confirm».

16 Embroidery

16.1 Embroidering via the Button «Start/Stop»

In case of a power cut the embroidery process is interrupted. After the restart the machine goes to the position which was embroidered last.



- > Push the button «Start/Stop» until the embroidery machine starts.
 - All parts of the motif being in the current color are embroidered.
 - The embroidery machine stops automatically at the end.
 - Both threads are cut automatically.
 - The embroidery machine switches to the next color automatically.



- > Change the upper thread.
- > To embroider the new color, push the button «Start/Stop».
 - After finishing the embroidery design, the machine stops automatically and the threads are cut automatically.

16.2 Increasing the Embroidery Speed

To ensure the best embroidery quality, the speed when embroidering is reduced depending on the embroidery position. Choose between the two options to either embroider at optimal or maximum speed. Standard = optimal speed. It has to be considered that the quality of the embroidered embroidery design at maximum speed cannot be ensured.

By switching the machine off and on, the optimal embroidery speed is activated.

Prerequisite:

- The embroidery design is selected.



- > Tap «Embroidery Speed».
 - The maximum speed is activated.
- > Tap «Embroidery Speed» again.
 - The optimal speed is activated.

16.3 Adjusting the Upper Thread Tension

The default setting of the upper thread tension is set automatically as soon as a stitch pattern or an embroidery design is selected.

The upper thread tension is set optimally at the BERNINA factory and the machine has been tested. Metrosene/Seralon thread size 100/2 (Mettler, Switzerland) is used for the upper and bobbin thread.

When using different types of sewing or embroidery threads, the upper thread tension may vary. Therefore it may be necessary to adjust the upper thread tension according to the sewing or embroidering project as well as the desired stitch pattern or the embroidery design individually.

The higher the upper thread tension is set, the tighter the upper thread is tensioned, and the bobbin thread is pulled deeper into the fabric. When the upper thread tension is low, the upper thread is less tightened, and the bobbin thread is pulled up less into the fabric.

Alterations of the upper thread tension affect the currently selected stitch pattern and all embroidery designs. (see page 48) Permanent alterations of the upper thread tension for the sewing mode and for the embroidering mode (see page 51) can be made in the Setup Program.

Prerequisite:

- The upper thread tension has been altered in the Setup Program.



- > Tap «Upper Thread Tension».

17 Care and Maintenance

17.1 Firmware

Checking the Firmware Version

The machine's firmware and hardware versions are displayed.



> Tap «Home».



> Tap «Setup Program».



> Tap «Machine Settings».



> Tap «Information».



> Tap «Machine Data».

Updating Firmware



The machine's current firmware and detailed step-by-step instructions for the update process can be downloaded from www.bernina.com. In general, personal data and settings are automatically transferred during a firmware update. For safety reasons, it is also recommended to save data and settings on a BERNINA USB stick before the firmware update is started. If personal data and settings should be lost during a firmware update, they can be transferred to the machine again afterwards.

Prerequisite:

- Accessories such as the Embroidery module or the BSR Foot which are connected to the machine have been removed.

> Insert the USB stick with the new firmware version into the machine.



> Tap «Home».



> Tap «Setup Program».



> Tap «Machine Settings».



> Tap «Maintenance/update».



> Tap «Updating firmware».



> To start the firmware update, tap «Update»

. **Please note:** The update may take several minutes. During the update, do not switch the machine off and do not remove the USB stick.

– The machine restarts. Once the update is complete, a message appears.

Recovering Saved Data

If personal data and settings after a software update are not available anymore, they can be transferred to the machine again afterwards.

> Insert the BERNINA USB stick which provides the saved data and settings into the USB port of the machine.

- > Tap «Home».
- > Tap «Setup Program».
- > Tap «Machine Settings».
- > Tap «Maintenance/update».
- > Tap «Updating firmware».

NOTICE

BERNINA USB Stick (Optional Accessory) has been removed too early

Saved data cannot be transferred and the machine cannot be used.

- > Remove the BERNINA USB stick (optional accessory) only after the saved data has been transferred successfully.



- > Tap «Load Data».
 - After the data has been transferred, a green tick is temporarily displayed.

17.2 Machine**Cleaning the Display**

- > Clean the display when it is switched off with a soft slightly damp microfiber cloth.

Cleaning the Feed Dog

Remaining threads under the stitch plate must occasionally be removed.

- > Raise the needle and presser foot.

CAUTION**Electronically Driven Components**

Risk of injury near the needle and the hook.

- > Switch the machine off and disconnect it from the power supply system.

- > Remove the needle and presser foot.
- > Lower feed dog.



- > Remove the stitch plate.

NOTICE**Dust and Thread Residues Inside the Machine**

Damage to mechanical and electronic components.

- > Use a brush or a soft cloth.
- > Do not use compressed air spray.

- > Clean the feed dog with the brush.

Cleaning the Hook

CAUTION

Electronically Driven Components

Risk of injury near the needle and the hook.

> Switch the machine off and disconnect it from the power supply system.

- > Open the hook cover.
- > Remove the bobbin case.
- > Push the release bracket to the left.



- > Flap down the fastening bracket along with the black hook race cover.
- > Remove the hook.

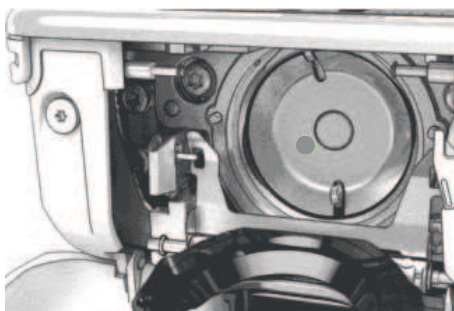

NOTICE

Dust and Thread Residues Inside the Machine

Damage to mechanical and electronic components.

- > Use a brush or a soft cloth.
- > Do not use compressed air spray.

- > Clean the hook race area with a brush and a soft cloth. Never use any sharp instruments.
- > Hold the hook at the pin in the center with two fingers.
- > Guide the hook with the lower edge diagonally from the top to the bottom behind the hook race cover.
- > Position the hook so that the two lugs on the hook driver fit into the corresponding openings on the hook, and the colored marking on the hook driver is visible in the hole of the hook.
- > Insert the hook.
 - The hook is magnetic and therefore fastened to the correct position.
- > Close the hook race cover and the fastening bracket until the release bracket engages.
- > As a check, turn the handwheel.
- > Insert the bobbin case.

Lubricating the Hook

By oiling the hook, the occurrence of unwanted noises in the hook area can be avoided. BERNINA recommends oiling the hook at the following intervals:

- Before using the machine for the first time
- After a longer downtime of the machine
- For intensive use: Daily before sewing
- When the message " Lubricate the Machine " is displayed
- In case of unwanted noises in the hook area

CAUTION**Electronically Driven Components**

Risk of injury near the needle and the hook.

- > Switch the machine off and disconnect it from the power supply system.

- > Remove the bobbin case.
- > Push the release bracket to the left.

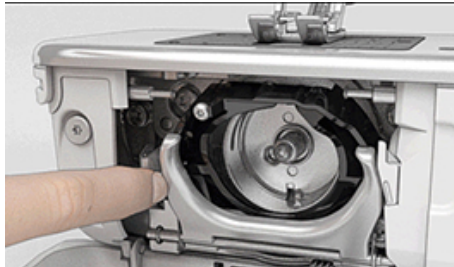

- > Flap down the fastening bracket along with the black hook race cover.
- > Remove the hook.

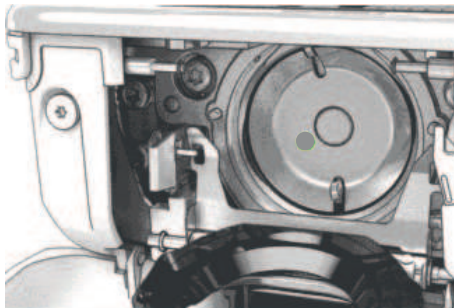

- > Clean the hook race area with a brush and a soft cloth. Never use any sharp instruments.
- > Add one drop of BERNINA oil down into the hook race.







- > Add one drop of oil into each of the two oil depots so that the felts are damp, and make sure that the red-marked surface of the hook sleeve remains free of oil.





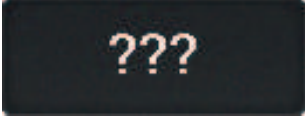
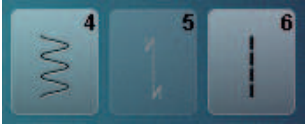
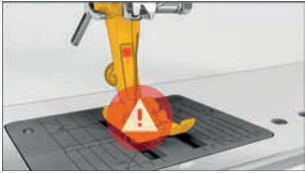

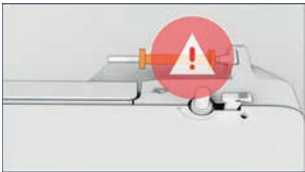

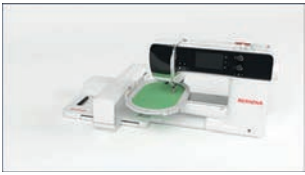
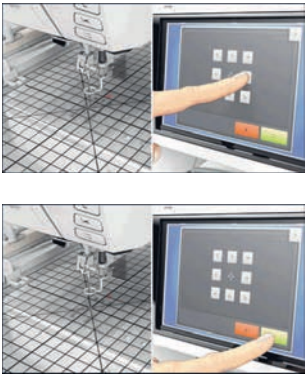

- > Hold the hook at the pin in the center with two fingers.
- > Guide the hook with the lower edge diagonally from the top to the bottom behind the hook race cover.
- > Position the hook so that the two lugs on the hook driver fit into the corresponding openings on the hook, and the colored marking on the hook driver is visible in the hole of the hook.
- > Insert the hook.
 - The hook is magnetic and therefore fastened to the correct position.

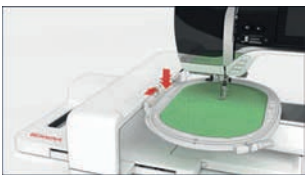
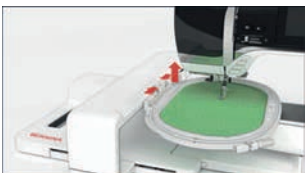
18 Errors and Faults

18.1 Error Messages

Message on the Display	Cause	Repair
	Stitch number unknown.	> Check the entry and enter the new number.
	Selection of stitch patterns not possible in combi-mode.	> Combine other stitch patterns.
	The feed dog is not lowered.	> To lower the feed dog, push the button «Feed Dog Up/Down».
	The selected needle and stitch plate cannot be used in combination.	> Replace the needle. > Replace the stitch plate.
	The needle is not at its top end.	> Adjust the needle position via the handwheel.
	The upper thread is used up.	> Rethread.
	The upper thread has broken.	> Rethread.
	The bobbin thread is used up.	> Rethread.
	The bobbin thread has broken.	> Clean the hook. > Rethread.

Message on the Display	Cause	Repair
	The main motor is not running.	<ul style="list-style-type: none"> > Turn the handwheel clockwise until the needle is at its top position. > Remove the stitch plate. > Remove the thread remnants. > Clean the hook. > Remove the hook and make sure that there are no pieces of broken needle points on the magnetic back of the hook. > Insert the hook correctly.
	The contact between the machine and the embroidery module is interrupted as a result of vibrations.	<ul style="list-style-type: none"> > Make sure that the embroidery module and the machine are standing on a stable, even surface. > Connect the embroidery module to the machine.
	The needle position doesn't correspond with the center of the hoop.	<ul style="list-style-type: none"> > Calibrate the hoop.
	The embroidery module is not attached.	<ul style="list-style-type: none"> > Connect the embroidery module to the machine. > Contact the specialized BERNINA dealer to have the machine checked.
	The hoop is not attached.	<ul style="list-style-type: none"> > Attach the hoop.
	The hoop is attached.	<ul style="list-style-type: none"> > Remove the hoop.
	The movement of the hoop follows.	<ul style="list-style-type: none"> > Tap «Confirm».



Message on the Display	Cause	Repair
	Mega Hoop top.	> Bring the Mega Hoop to the top position.
	Mega Hoop center.	> Bring the Mega Hoop to the center position.
	Mega Hoop bottom.	> Bring the Mega Hoop to the lower position.
	The embroidery design is partly outside the hoop.	> Reposition the embroidery design and start embroidering it again.
	The embroidery design is too large.	<ul style="list-style-type: none"> > Reduce the size of the embroidery design. > Attach a larger hoop.
Not enough free capacity on the BERNINA USB stick (optional accessory).	There is not enough free capacity on the BERNINA USB stick (optional accessory).	<ul style="list-style-type: none"> > Make sure that the BERNINA USB stick (optional accessory) is used. > Delete data from the BERNINA USB stick (optional accessory).
No personal data on the BERNINA USB stick (optional accessory).	No personal data for recovery available on the BERNINA USB stick (optional accessory).	> Make sure that the data and settings have been saved on the BERNINA USB stick (optional accessory).
The recovery of personal data has failed.	The firmware update has been successful but the personal data could not be recovered.	<ul style="list-style-type: none"> > Make sure that the data and settings have been saved on the BERNINA USB stick. > Transfer saved data to the machine.

Message on the Display	Cause	Repair
No BERNINA USB stick is inserted. Make sure that the same BERNINA USB stick remains connected during the entire automatic update process.	The BERNINA USB stick (optional accessory) is not inserted.	<ul style="list-style-type: none"> > Use a BERNINA USB stick (optional accessory) which provides enough free capacity.
The firmware update has failed.	The latest firmware version cannot be found on the USB stick.	<ul style="list-style-type: none"> > Make sure that the compressed zip file has been unzipped for the firmware update. > Check whether the data for the software update is saved directly on the data medium and not in a file on the USB stick. > Updating Firmware.
	The machine must be cleaned/ lubricated.	<ul style="list-style-type: none"> > Clean the machine. > Lubricate the hook. <p>Important Information on Lubricating: Too much oil may stain the fabric and the thread.</p> <ul style="list-style-type: none"> > After lubricating, sew/embroider a test piece first.
The automatic thread cutter (at the thread catcher) needs cleaning.	The automatic thread cutter needs cleaning. The message appears every time when the machine is started as soon as 1000 cutting cycles have been carried out.	<ul style="list-style-type: none"> > Tap «Confirm». <ul style="list-style-type: none"> – The machine calls up the function «Clean the Thread Catcher». > Clean the thread catcher according to the instructions on the display. <ul style="list-style-type: none"> – The counter for the cutting cycles is reset.

Message on the Display	Cause	Repair
It is time for the regular maintenance. Please contact your authorized BERNINA dealer to make an appointment.	<p>The machine needs maintenance. The message appears after the programmed service interval has expired.</p> <p>Important Information: Having your machine cleaned and serviced properly at the appropriate times ensures its proper functioning and a long service life. In case of non-compliance, the service life may be negatively affected and the warranty service may possibly become limited. The cost allocation for maintenance work is regulated nationally. Consult your authorized BERNINA dealer or your service center for more details.</p>	<ul style="list-style-type: none"> > Contact an authorized BERNINA dealer. > Delete the message temporarily by touching the icon «ESC». <p>After the third deletion, the message is not displayed until the next service interval is reached.</p>
	<p>The calibration of the Buttonhole Foot with Slide #3A has failed.</p>	<ul style="list-style-type: none"> > Check the presser foot for ease of movement. If necessary, remove lint, dust and fabric remnants. > Clean the reflector with a soft, slightly damp microfiber cloth. > Check the position of the reflector. If necessary, correct the position of the reflector or replace the presser foot. > Check the plastic on the underside of the presser foot for signs of wear. If necessary, replace the presser foot. > Clean the feed dog. > If the error still occurs, contact your authorized BERNINA dealer.

18.2 Troubleshooting

Fault	Cause	Repair
Uneven Stitch Formation	Upper thread too tight or too loose.	<ul style="list-style-type: none"> > Adjust the upper thread tension. > Check the thread feed from the thread spool.
	Needle blunt or bent.	> Replace the needle, make sure that a new BERNINA quality needle is used.
	Poor quality needle.	> Use a new BERNINA quality needle.
	Poor quality thread.	> Use quality thread.
	Incorrect needle/thread combination.	> Match the needle with the thread size.
	Incorrectly threaded.	> Rethread.
	The fabric has been pulled.	> Feed the fabric evenly.

Fault	Cause	Repair
Uneven Stitch Formation 	Incorrect bobbin case is used.	> Use the supplied bobbin case marked with the triangle.
	<hr/>	
Skipped Stitches	Incorrect needle.	> Use the needle system 130/705H.
	Needle blunt or bent.	> Replace the needle.
	Poor quality needle.	> Use a new BERNINA quality needle.
	The needle is incorrectly inserted.	> Insert the needle with the flat side to the back as far up as it will go into the needle holder and tighten the screw.
	Incorrect needle point.	> Match the needle point to the texture of the material.
Faulty Stitching	Thread remnants between the thread tension discs.	> Fold a piece of thin material and slide the folded edge (not the raw edges) between the thread tension discs.
	Incorrectly threaded.	> Rethread.
	Thread remnants below the bobbin case spring.	> Remove the thread remnants under the spring.
Upper Thread Breaks	Incorrect needle/thread combination.	> Match the needle with the thread size.
	Upper thread is too tight.	> Reduce the upper thread tension.
	Incorrectly threaded.	> Rethread.
	Poor quality thread.	> Use quality thread.
	The stitch plate or the hook tip is damaged.	> Contact the nearest specialized BERNINA dealer to have the damages repaired. > Replace the stitch plate.
	The thread is caught in the area of the thread take-up lever.	> Slide the headframe (1) to the left, then remove it. > Remove the thread remnants. > Insert the 4 knobs of the headframe into the provided notches and slide the headframe to the right.
		

Fault	Cause	Repair
Lower Thread Breaks	The bobbin case is damaged.	> Replace the bobbin case.
	The stitch hole in the stitch plate damaged.	> Contact the nearest specialized BERNINA dealer to have the damages repaired. > Replace the stitch plate.
	Needle blunt or bent.	> Replace the needle.
Needle Breaks	The needle is incorrectly inserted.	> Insert the needle with the flat side to the back as far up as it will go into the needle holder and tighten the screw.
	The fabric has been pulled.	> Feed the fabric evenly.
	Thick fabric has been pushed.	> Use a suitable presser foot, e. g. Jeans Foot #8, for thick fabric. > Use the height compensating tool when sewing over a thick seam.
	Knotted thread.	> Use quality thread.
Stitch Width Not Adjustable	The selected needle and stitch plate cannot be used in combination.	> Replace the needle. > Replace the stitch plate.
Speed Too Low	Unfavorable room temperature.	> Place the machine in a warm room one hour before use.
	Settings in the Setup Program.	> Adjust the sewing speed in the Setup Program. > Adjust the slide.
The Machine doesn't Start	Unfavorable room temperature.	> Place the machine in a warm room one hour before use. > Connect the machine and switch it on.
	The machine is damaged.	> Contact an authorized BERNINA dealer.
Neither the Sewing Light Nor the Light on the Freearm Lights Up	Settings in the Setup Program.	> Activate it in the Setup Program.
	The sewing light is defect.	> Contact an authorized BERNINA dealer.
Upper Thread Indicator Fails to Respond	Settings in the Setup Program.	> Activate it in the Setup Program.
	The upper thread indicator is defect.	> Contact an authorized BERNINA dealer.
Bobbin Thread Indicator doesn't React	Settings in the Setup Program.	> Activate it in the Setup Program.
	The bobbin thread indicator is defect.	> Contact an authorized BERNINA dealer.

Fault	Cause	Repair
Error During Firmware Update	USB stick is not recognized.	> Use the BERNINA USB stick.
	The update process is blocked and the hourglass on the display is inactive.	> Remove the USB stick. > Switch the machine off. > Switch the machine on. > Follow the instruction on the display.
	Firmware update files are not found.	> Unzip the update data. > Store data for the firmware update directly on the data medium and not in a folder on the USB stick.
BSR Presser Foot #42 Not Detected	Lens is dirty.	> Clean the lens with a soft, slightly damp cloth.
	BSR cable not inserted correctly.	> Insert the BSR connector vertically until it can be felt to click into place.
Beads and/or Bartacks are Repeatedly Not Sewn Properly	The Buttonhole Foot with Slide #3A is not calibrated with the machine.	> Calibrate Buttonhole Foot with Slide #3A.

19 Storage and Disposal

19.1 Storing the Machine

It is recommended to store the machine in the original packaging. If the machine is stored in a cold room, place it in a warm room one hour before use.

- > Switch the machine off and disconnect it from the power supply.
- > Don't store the machine outdoors.
- > Protect the machine against climatic influences.

19.2 Dispose of the Machine

- > Clean the machine.
- > Sort the components by their materials and dispose of them according to the local laws and regulations.

20 Technical Data

Designation	Value	Unit
Maximum Fabric Thickness	10.5 (0.41)	mm (in)
Maximum Speed	1000	Stitches per Minute
Foot Control	LV-1	
Needle System	130/705	
Measurements without the Spool Pin (W × H × D)	450 × 330 × 200 (17.72 × 12.99 × 7.87)	mm (in)
Measurements incl. Embroidery Module without Spool Pin (W × H × D)	750 × 330 × 450 29.53 × 12.99 × 17.72	mm (in)
Weight of the Machine	11.2 (25.35)	kg (lb)
Weight of the Embroidery Module	3.7 6.6	kg (lb)
Energy Consumption	90	W
Input Voltage	100 – 240 50 - 60	V Hz
Protection Class (Electrical Engineering)	II	

21 Overview Stitch Patterns

21.1 Overview Stitch Patterns

Practical Stitches

1	2	3	4	5	6	7	8	9	10	11	12	13	14
15	16	17	18	19	20	22	23	24	25	26	27	29	30
32	33	34	35	36	37								

Buttonholes

51	52	53	54	55	56	57	58	59	60	61	62	63	64
65	67	69											

Decorative Stitches

Nature Stitches

101	102	103	104	106	107	108	109	110	111	112	113	114	115
116	117	118	119	122	123	124	125	129	130	131	132	137	138
139	140	141	142	143	144	145	146	150	152	153	154	155	156
159	160	161	167	168	169	170	171	174	175	176	177	178	179
180	181	182	183	184	185								

Cross Stitches



301	302	303	304	305	306	307	308	309	314	319	320	321	322
323	324	325	326	327	328	329	330	331	332	333	334	335	336
337	338	339	371	372	373								

Satin Stitches

































































401	402	405	406	407	408	409	410	412	413	414	415	416	417
418	419	421	422	423	424	425	426	427	428	429	431	433	434
436	437	440	442	443	444	445	447	448	449	453	454	455	456
461	465	466	471	472	473								

Geometric Stitches















































601	602	603	604	605	606	607	608	609	610	611	612	613	614
615	616	618	619	620	621	622	623	624	625	626	627	628	629
630	631	632	633	634	635	636	637	639	640	641	642	643	644
645	646	647	648	649	650	651	652	653	654	655	656	657	658
660	661	662	663	664	665	666	677	678	679	680	682	683	684

685 	686 	691 
--	--	--

















White Embroidery

701 	702 	703 	704 	705 	706 	707 	708 	709 	710 	711 	712 	713 	714 
715 	716 	717 	721 	722 	723 	724 	725 	726 	727 	729 	730 	731 	732 
733 	734 	735 	736 	737 	738 	739 	740 	741 	742 	743 	744 	745 	746 
747 	748 	749 	750 	751 	752 	756 	769 	770 	771 	772 	773 	774 	775 
776 	777 	778 	779 	780 	781 	782 	783 						

Children Stitches

901 	902 	903 	904 	905 	906 	907 	908 	909 	910 	911 	912 	913 	914 
915 	916 	917 	918 	919 	920 	921 	922 	924 	926 	928 	929 	935 	937 
938 	939 	940 	944 	945 	946 	948 	949 	950 	952 	954 	955 	957 	958 
959 	960 	961 	962 										

Special Stitches

1101 	1102 	1103 	1104 	1105 	1106 	1107 	1108 	1109 	1110 	1113 	1115 	1116 	1121 
1122 	1124 												

International

1701	1702	1703	1704	1705	1706	1707	1708	1709	1710	1711	1715	1716	1717
1718	1719	1720	1721	1722	1723								

Seasons

2001	2002	2003	2004	2005	2006	2007	2008	2009	2015	2017	2019	2022	2023

Quilt Stitches

1301	1302	1303	1304	1305	1306	1307	1308	1309	1310	1311	1312	1313	1314
				6 / inch 2.4 / cm	8 / inch 3.2 / cm	10 / inch 4 / cm	irregular look						
1315	1316	1317	1318	1319	1320	1321	1322	1323	1324	1325	1326	1327	1329
1330	1331	1332	1333	1334	1335	1336	1337	1338	1339	1340	1341	1342	1343
1344	1345	1346	1363	1364	1365	1366	1367	1368	1369	1370	1371	1373	1374
1375	1376	1377	1378	1379	1380	1381	1382	1384	1385	1386	1387	1388	1389
1390	1391	1393	1394										













21.2 Overview Embroidery Designs

Editing the Embroidery Design



















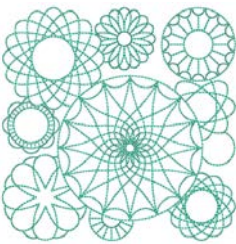







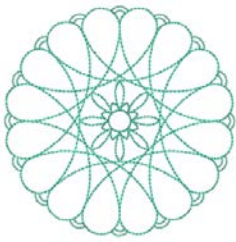

Let your creativity run free. A vast selection of embroidery designs is at your disposal.

If you see one of the following pictograms below a number of the embroidery design, you can find additional information at







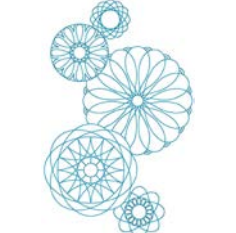

















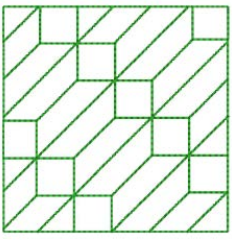





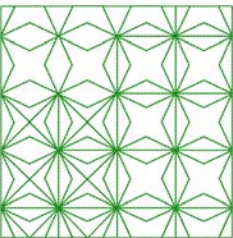

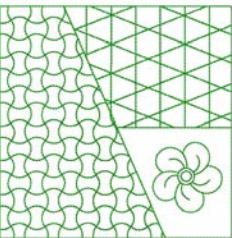





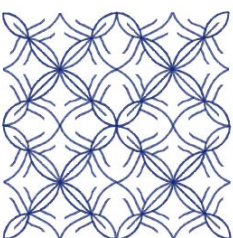

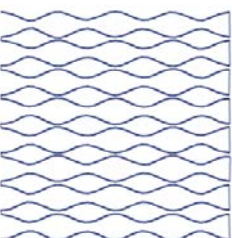



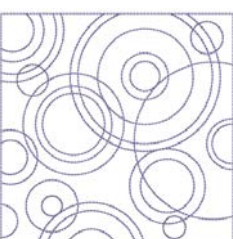

<https://www.bernina.com/specialeffects>.

	Detached Point		PunchWork
	Basic CutWork		Couching
	Fringe Embroidery		Projects in the Hoop
	Appliqué		Puffy Fonts
	CutWork		Quilting
	PaintWork		Trapunto
	CrystalWork		

Quilt Designs

 12380-43  123 x 123 mm 4.9 x 4.9 inch  8.248	 12499-23  123 x 123 mm 4.9 x 4.9 inch  11.194
1.  Isacord 40 1543 	1.  Isacord 40 5115 
 12499-06  102 x 102 mm 4 x 4 inch  3.838	 12499-04  123 x 123 mm 4.9 x 4.8 inch  7.229
1.  Isacord 40 5115 	1.  Isacord 40 5610 
 12499-05  123 x 123 mm 4.9 x 4.9 inch  6.317	 12499-24  133 x 215 mm 5.2 x 8.4 inch  11.445
1.  Isacord 40 4103 	1.  Isacord 40 4103 

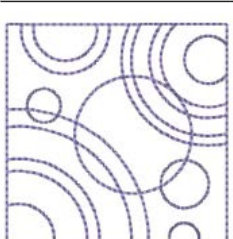
Overview Stitch Patterns

<p>12416-04  89 x 89 mm 3.5 x 3.5 inch  3.482</p>	<p>12416-03  124 x 124 mm 4.9 x 4.9 inch  5.909</p>
<p>1.  Isacord 40 0721</p> 	<p>1.  Isacord 40 0721</p> 
<p>12416-26  44 x 174 mm 1.7 x 6.9 inch  2.816</p>	<p>Nb347_48  76 x 76 mm 3 x 3 inch  2.337</p>
<p>1.  Isacord 40 3830</p> 	<p>1.  Isacord 40 5513</p> 
<p>Nb334_48  127 x 127 mm 5 x 5 inch  6.838</p>	<p>Nb335_48  127 x 127 mm 5 x 5 inch  7.971</p>
<p>1.  Isacord 40 5513</p> 	<p>1.  Isacord 40 5513</p> 
<p>Nz498  89 x 89 mm 3.5 x 3.5 inch  2.642</p>	<p>Nz503  99 x 99 mm 3.9 x 3.9 inch  2.103</p>
<p>1.  Isacord 40 3353</p> 	<p>1.  Isacord 40 3353</p> 
<p>82013-29  121 x 121 mm 4.8 x 4.8 inch  5.644</p>	<p>82013-30  83 x 166 mm 3.3 x 6.5 inch  2.774</p>
<p>1.  Isacord 40 2920</p> 	<p>1.  Isacord 40 2920</p> 
<p>82013-31  57 x 58 mm 2.3 x 2.3 inch  1.884</p>	<p>82013-32  122 x 105 mm 4.8 x 4.1 inch  4.506</p>
<p>1.  Isacord 40 2920</p> 	<p>1.  Isacord 40 2920</p> 



12416-24 89 x 73 mm 2.330
3.5 x 2.9 inch

1. Isacord 40 3830



12607-16 123 x 122 mm 1.222
4.8 x 4.8 inch

1. Isacord 40 0020



12616-16 123 x 123 mm 1.198
4.8 x 4.8 inch

1. Isacord 40 5422



12380-22 110 x 61 mm 2.487
4.4 x 2.4 inch

1. Isacord 40 1543



12380-30 89 x 96 mm 4.442
3.5 x 3.8 inch

1. Isacord 40 1543



12380-04 83 x 90 mm 2.189
3.3 x 3.5 inch

1. Isacord 40 1543



12380-08 89 x 89 mm 2.725
3.5 x 3.5 inch

1. Isacord 40 1543



Bd800_48 126 x 122 mm 609
5 x 4.8 inch

1. Isacord 40 3654

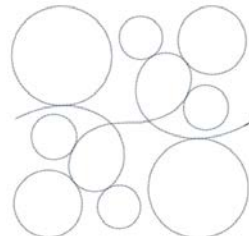

Bd804_48 123 x 124 mm 904
4.8 x 4.9 inch

1. Isacord 40 0111

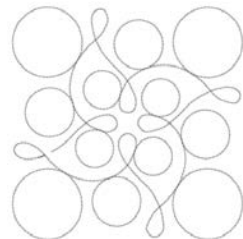

Bd796_48 47 x 173 mm 521
1.9 x 6.8 inch

1. Isacord 40 3654



Bd837_48 123 x 123 mm 1.629
4.9 x 4.9 inch

1. Isacord 40 0138







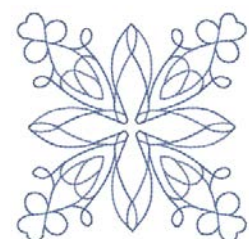

















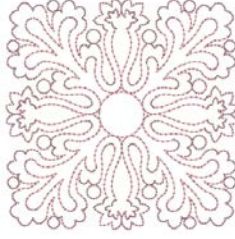





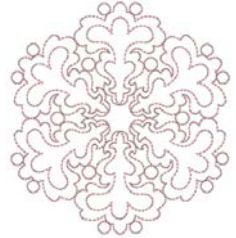















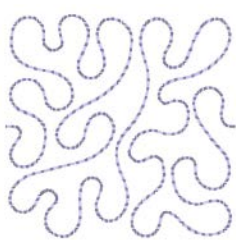

Bd292 95 x 95 mm 3.036
3.7 x 3.7 inch

1. Isacord 40 3332



Overview Stitch Patterns

Bd299  94 x 95 mm 3.7 x 3.7 inch  3.133	Bd308  95 x 94 mm 3.7 x 3.7 inch  3.763
1.  Isacord 40 0700 	1.  Isacord 40 1311 
Bd413_48  97 x 97 mm 3.8 x 3.8 inch  4.124	Bd554_48  110 x 110 mm 4.3 x 4.3 inch  6.252
1.  Isacord 40 5822 	1.  Isacord 40 2153 
Bd553_48  114 x 121 mm 4.5 x 4.8 inch  5.845	Bd567_48  108 x 108 mm 4.3 x 4.3 inch  4.359
1.  Isacord 40 2153 	1.  Isacord 40 2530 
Bd394_48  97 x 97 mm 3.8 x 3.8 inch  4.586	Bd412_48  89 x 53 mm 3.5 x 2.1 inch  1.427
1.  Isacord 40 3641 	1.  Isacord 40 1335 
Bd501_48  64 x 61 mm 2.5 x 2.4 inch  1.202	Bd502_48  62 x 61 mm 2.4 x 2.4 inch  1.139
1.  Isacord 40 3151 	1.  Isacord 40 3151 
Bd513_48  64 x 63 mm 2.5 x 2.5 inch  950	Bd514_48  64 x 63 mm 2.5 x 2.5 inch  926
1.  Isacord 40 1532 	1.  Isacord 40 1352 



Bd562_48 64 x 126 mm 2.5 x 5 inch 2.322

1. Isacord 40 5531



Bd568_48 110 x 160 mm 4.3 x 6.3 inch 6.137

1. Isacord 40 3151



Bd563_48 90 x 90 mm 3.5 x 3.5 inch 2.482

1. Isacord 40 5531



Bd569_48 120 x 120 mm 4.7 x 4.7 inch 6.183

1. Isacord 40 1220



Embellishment

Nb826_48 135 x 133 mm 5.3 x 5.2 inch 11.154

1. Isacord 40 9971
2. Isacord 40 9978
3. Isacord 40 9973
4. Isacord 40 1972



Nb843_48 87 x 121 mm 3.4 x 4.8 inch 8.976

1. Isacord 40 9971
2. Isacord 40 9937
3. Isacord 40 9925
4. Isacord 40 9975
5. Isacord 40 9978
6. Isacord 40 9973
7. Isacord 40 9982
8. Isacord 40 1972



12633-06 120 x 120 mm 4.7 x 4.7 inch 18.023

1. Isacord 40 0015



12473-06 133 x 120 mm 5.3 x 4.7 inch 11.358

1. Isacord 40 4610
2. Isacord 40 5633



12473-04 94 x 184 mm 3.7 x 7.3 inch 11.531

1. Isacord 40 5552
2. Isacord 40 5374



Be790403 140 x 130 mm 5.5 x 5.1 inch 13.281

1. Isacord 40 0020
2. Isacord 40 0731



80090-06

84 x 37 mm
3.3 x 1.4 inch

3.766

1. Applique 1
2. Applique 2
3. Isacord 40 4103



80090-07

128 x 36 mm
5 x 1.4 inch

5.450

1. Applique 1
2. Applique 2
3. Isacord 40 5440



19999-002

125 x 136 mm
4.9 x 5.4 inch

10.184

1. Isacord 40 0015
2. Isacord 40 0015
3. Isacord 40 0015



Nb934_48

132 x 165 mm
5.2 x 6.5 inch

9.168

1. Isacord 40 2241
2. Isacord 40 1154
3. Isacord 40 1346
4. Isacord 40 1161
5. Isacord 40 2222
6. Isacord 40 5833
7. Isacord 40 1154
8. Isacord 40 2241



Nb935_48

104 x 169 mm
4.1 x 6.6 inch

10.171

1. Isacord 40 2222
2. Isacord 40 1346
3. Isacord 40 0232
4. Isacord 40 1154
5. Isacord 40 5833
6. Isacord 40 2241



21021-05

119 x 156 mm
4.7 x 6.1 inch

14.326

1. Isacord 40 1252
2. Isacord 40 1161
3. Isacord 40 1565



21021-04

123 x 150 mm
4.8 x 5.9 inch

16.176

1. Isacord 40 1161
2. Isacord 40 1252
3. Isacord 40 1565



21021-06

116 x 109 mm
4.6 x 4.3 inch

12.204

1. Isacord 40 1161
2. Isacord 40 1252
3. Isacord 40 1565



12490-03

118 x 113 mm
4.6 x 4.5 inch

6.669

1. Isacord 40 0108
2. Isacord 40 3641
3. Isacord 40 3652



12490-04

146 x 122 mm
5.8 x 4.8 inch

8.724

1. Isacord 40 0108
2. Isacord 40 3641
3. Isacord 40 3652



12490-05

126 x 104 mm
4.9 x 4.1 inch

6.148

1. Isacord 40 0108
2. Isacord 40 3641
3. Isacord 40 3652



12528-12



124 x 124 mm
4.9 x 4.9 inch

39.751



1. Isacord 40 0931
2. Isacord 40 0824
3. Isacord 40 0851





12528-03  76 x 130 mm
3 x 5.1 inch  16.171



1.  Isacord 40 0851
2.  Isacord 40 0824
3.  Isacord 40 0931













Oc07207  106 x 138 mm
4.2 x 5.4 inch  17.807



1.  Yenmet 7012
2.  Isacord 40 0670
3.  Yenmet 7012





 **82007-11**  112 x 94 mm
4.4 x 3.7 inch  13.622



1.  Applique 1
2.  Applique 3
3.  Applique 1
4.  Applique 3
5.  Applique 1
6.  Isacord 40 1805
7.  Isacord 40 2152
8.  Isacord 40 2520
9.  Isacord 40 2500
10.  Isacord 40 2115
11.  Isacord 40 0761













82007-44  114 x 115 mm
4.5 x 4.5 inch  9.467



1.  Isacord 40 2152
2.  Isacord 40 2520







 **82006-30**  100 x 174 mm
3.9 x 6.9 inch  21.584

1.  Isacord 40 0020
2.  Isacord 40 4174
3.  Isacord 40 0020
4.  Isacord 40 4174
5.  Isacord 40 0771
6.  Isacord 40 0832
7.  Isacord 40 0108
8.  Isacord 40 4174
9.  Isacord 40 0660
10.  Isacord 40 1526



Nb251_48  72 x 103 mm
2.8 x 4.1 inch  8.612



1.  Isacord 40 2155
2.  Isacord 40 2504
3.  Isacord 40 0020
4.  Isacord 40 0020





Be790405  126 x 185 mm
4.9 x 7.3 inch  7.734



1.  Isacord 40 3102



Fb126  87 x 102 mm
3.4 x 4 inch  2.668

1.  Isacord 40 1220
2.  Isacord 40 1805





Be790502  60 x 58 mm
2.4 x 2.3 inch  1.814

1.  Isacord 40 3541





 **21003-26**  123 x 124 mm
4.8 x 4.9 inch  16.269

1.  Isacord 40 0345
2.  Isacord 40 0442
3.  Isacord 40 0232



Overview Stitch Patterns

Nb403_48  78 x 78 mm
3.1 x 3.1 inch  6.615

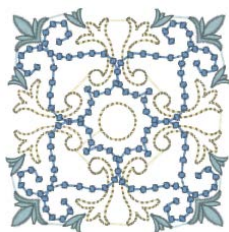

1.  Isacord 40 0552
2.  Isacord 40 4032
3.  Isacord 40 4332





Nb373_48  121 x 177 mm
4.8 x 7 inch  9.769

1.  Isacord 40 4531





Nb442_48  56 x 58 mm
2.2 x 2.3 inch  809



1.  Isacord 40 5610
2.  Isacord 40 5643
3.  Isacord 40 3630



























Nb481_48  123 x 68 mm
4.9 x 2.7 inch  7.043

1.  Isacord 40 0870
2.  Isacord 40 0670











Nb749_48  126 x 263 mm
5 x 10.4 inch  16.792

1.  Isacord 40 6051
2.  Isacord 40 1805
3.  Isacord 40 0182
4.  Isacord 40 9405
5.  Isacord 40 0800
6.  Isacord 40 0904
7.  YLI variations 8001
8.  Isacord 40 0600
9.  Isacord 40 0184
10.  Isacord 40 0552
11.  Isacord 40 1921
12.  YLI variations 8019
13.  YLI variations 8016
14.  Isacord 40 1600
15.  Isacord 40 1904
16.  YLI variations 8020
17.  Isacord 40 5912
18.  YLI variations 8004
19.  Isacord 40 5722
20.  Isacord 40 5510
21.  Isacord 40 0151
22.  Isacord 40 0232
23.  Isacord 40 6133
24.  YLI variations 8013





Na959_48  75 x 103 mm
3 x 4.1 inch  10.645



1.  Isacord 40 6051
2.  Isacord 40 5650
3.  Isacord 40 6051
4.  Isacord 40 2761
5.  Isacord 40 1141
6.  Isacord 40 4010
7.  Isacord 40 4240
8.  Isacord 40 0670





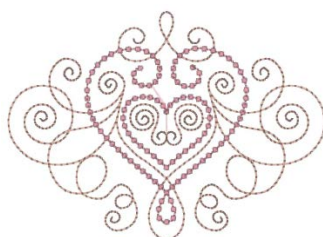



Fb106  128 x 92 mm
5 x 3.6 inch  4.433

1.  Isacord 40 1061
2.  Isacord 40 2241







Nb002_48  59 x 35 mm
2.3 x 1.4 inch  3.307

1.  Isacord 40 0310
2.  Isacord 40 3962
3.  Isacord 40 2560
4.  Isacord 40 1904
5.  Isacord 40 3040
6.  Isacord 40 3543
7.  Isacord 40 2905













Ws655_48  116 x 222 mm
4.6 x 8.8 inch  17.135













































































1.  Isacord 40 3910
2.  Isacord 40 0862
3.  Isacord 40 1725
4.  Isacord 40 0761









Flowers

<p>21012-04</p>	<p>123 x 124 mm 4.9 x 4.9 inch</p>	<p>21027-01</p>	<p>123 x 122 mm 4.8 x 4.8 inch</p>
<p>1. Isacord 40 5740 2. Isacord 40 0142 3. Isacord 40 0020 4. Isacord 40 5531 5. Isacord 40 4240 6. Isacord 40 0015 7. Isacord 40 0020 8. Isacord 40 3710 9. Isacord 40 3920 10. Isacord 40 0015</p>		<p>1. Isacord 40 1805 2. Isacord 40 2721 3. Isacord 40 2520 4. Isacord 40 5100 5. Isacord 40 4114 6. Isacord 40 4103 7. Isacord 40 0506 8. Isacord 40 5115</p>	
<p>21027-14</p>	<p>121 x 121 mm 4.8 x 4.8 inch</p>	<p>21027-16</p>	<p>57 x 152 mm 2.3 x 6 inch</p>
<p>1. Isacord 40 5115 2. Isacord 40 2721 3. Isacord 40 4114 4. Isacord 40 2520 5. Isacord 40 0506 6. Isacord 40 5100 7. Isacord 40 1805 8. Isacord 40 5115 9. Isacord 40 1805</p>		<p>1. Isacord 40 1805 2. Isacord 40 2520 3. Isacord 40 2721 4. Isacord 40 5100 5. Isacord 40 0506 6. Isacord 40 5115 7. Isacord 40 4114 8. Isacord 40 5115 9. Isacord 40 1805</p>	
<p>21027-17</p>	<p>57 x 152 mm 2.3 x 6 inch</p>	<p>21017-01</p>	<p>104 x 158 mm 4.1 x 6.2 inch</p>
<p>1. Isacord 40 1805 2. Isacord 40 2723 3. Isacord 40 2520 4. Isacord 40 5100 5. Isacord 40 0506 6. Isacord 40 4103 7. Isacord 40 4114 8. Isacord 40 5115 9. Isacord 40 1805</p>		<p>1. Isacord 40 0453 2. Isacord 40 0442 3. Isacord 40 0345 4. Isacord 40 1301 5. Isacord 40 0702 6. Isacord 40 1102 7. Isacord 40 0761 8. Isacord 40 0640</p>	
<p>F1136</p>	<p>85 x 89 mm 3.3 x 3.5 inch</p>	<p>F1142</p>	<p>79 x 86 mm 3.1 x 3.4 inch</p>
<p>1. Isacord 40 0311 2. Isacord 40 5326 3. Isacord 40 5374 4. Isacord 40 0101 5. Isacord 40 3951</p>		<p>1. Isacord 40 2830 2. Isacord 40 3541 3. Isacord 40 2830 4. Isacord 40 1912 5. Isacord 40 0108 6. Isacord 40 3842 7. Isacord 40 0453 8. Isacord 40 5326</p>	
<p>82006-07</p>	<p>124 x 166 mm 4.9 x 6.5 inch</p>	<p>21006-02</p>	<p>114 x 135 mm 4.5 x 5.3 inch</p>
<p>1. Isacord 40 4174 2. Isacord 40 0108 3. Isacord 40 0643 4. Isacord 40 0660 5. Isacord 40 0643 6. Isacord 40 4421 7. Isacord 40 1526 8. Isacord 40 0660 9. Isacord 40 4174</p>		<p>1. Isacord 40 3910 2. Isacord 40 3900 3. Isacord 40 0015 4. Isacord 40 3962 5. Isacord 40 3900 6. Isacord 40 0015</p>	

Overview Stitch Patterns





80001-23  85 x 102 mm 3.4 x 4 inch  4.257	12457-06  106 x 172 mm 4.2 x 6.8 inch  12.636
<ol style="list-style-type: none"> 1.  Isacord 40 1102 2.  Isacord 40 1805 3.  Isacord 40 6011 4.  Isacord 40 4174 	<ol style="list-style-type: none"> 1.  Isacord 40 3150 2.  Isacord 40 3210 3.  Isacord 40 0311 4.  Isacord 40 3331 5.  Isacord 40 3711 6.  Isacord 40 2250 7.  Isacord 40 2241 8.  Isacord 40 2051 
12457-13  113 x 130 mm 4.4 x 5.1 inch  6.676	21009-21  65 x 108 mm 2.6 x 4.2 inch  4.343
<ol style="list-style-type: none"> 1.  Isacord 40 6051 2.  Isacord 40 5730 3.  Isacord 40 5722 4.  Isacord 40 2905 5.  Isacord 40 0311 6.  Isacord 40 5115 7.  Isacord 40 5220 8.  Isacord 40 5100 	<ol style="list-style-type: none"> 1.  Isacord 40 5220 2.  Isacord 40 5210 
Be790408  58 x 90 mm 2.3 x 3.5 inch  2.045	21002-02  110 x 160 mm 4.3 x 6.3 inch  8.622
<ol style="list-style-type: none"> 1.  Isacord 40 3541 	<ol style="list-style-type: none"> 1.  Isacord 40 0933 2.  Isacord 40 1252 
Fb492_48  87 x 293 mm 3.4 x 11.5 inch  28.865	Fp814  88 x 84 mm 3.5 x 3.3 inch  3.677
<ol style="list-style-type: none"> 1.  Isacord 40 0132 2.  Isacord 40 0015 3.  Isacord 40 2250 4.  Isacord 40 2363 5.  Isacord 40 2560 6.  Isacord 40 2155 7.  Isacord 40 2153 8.  Isacord 40 0713 9.  Isacord 40 0142 10.  Isacord 40 0643 11.  Isacord 40 2152 	<ol style="list-style-type: none"> 1.  Isacord 40 5730 2.  Isacord 40 6141 3.  Isacord 40 1114 4.  Isacord 40 0660 
Fq562_48  90 x 156 mm 3.6 x 6.1 inch  5.843	Fq722_48  80 x 90 mm 3.1 x 3.6 inch  6.151
<ol style="list-style-type: none"> 1.  Isacord 40 5610 2.  Isacord 40 2830 	<ol style="list-style-type: none"> 1.  Isacord 40 3962 2.  Isacord 40 0670 3.  Isacord 40 5822 4.  Isacord 40 0776 5.  Isacord 40 1375 

Fq733_48  66 x 66 mm
2.6 x 2.6 inch  8.391

1.  Isacord 40 0670
2.  Isacord 40 5822
3.  Isacord 40 0776
4.  Isacord 40 1375











Nb209_48  90 x 90 mm
3.5 x 3.5 inch  8.140

1.  Isacord 40 4111
2.  Isacord 40 0722
3.  Isacord 40 1840
4.  Isacord 40 1335
5. Isacord 40 0015





Children

 **Ck859**  119 x 142 mm
4.7 x 5.6 inch  30.121

1.  Isacord 40 3815
2.  Isacord 40 0101
3.  Isacord 40 6141
4.  Isacord 40 0630
5.  Isacord 40 3910
6.  Isacord 40 0811
7. Isacord 40 0015
8.  Isacord 40 0904
9.  Isacord 40 3241
10.  Isacord 40 1701
13. Isacord 40 0015







11.  Isacord 40 4174
12.  Isacord 40 3815
14.  Isacord 40 2153

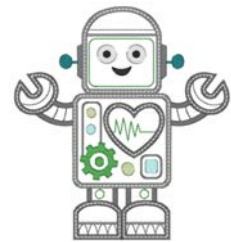









 **12590-03**  135 x 147 mm
5.3 x 5.8 inch  22.117

1.  Applique 1
2.  Applique 2
3.  Applique 1
4.  Applique 2
5.  Applique 1
6.  Applique 2
7.  Applique 1
8.  Applique 2
9. Isacord 40 0015
10.  Isacord 40 0020
13.  Isacord 40 4230
16.  Isacord 40 0112







11.  Isacord 40 5510
12.  Isacord 40 5650
14.  Isacord 40 4116
15.  Isacord 40 0132
17. Isacord 40 0015







 **Ck867**  122 x 133 mm
4.8 x 5.2 inch  28.880

1.  Applique 1
2.  Applique 2
3.  Applique 3
4.  Isacord 40 5730
5.  Isacord 40 2761
6.  Isacord 40 0630
7.  Isacord 40 3910
8. Isacord 40 0015
9.  Isacord 40 0811
10.  Isacord 40 2830
13.  Isacord 40 3722





11.  Isacord 40 4174
12.  Isacord 40 1701
14. Isacord 40 0015
15.  Isacord 40 1430

Cm031_48  86 x 64 mm
3.4 x 2.5 inch  6.433

1.  Isacord 40 5730
2.  Isacord 40 1352
3.  Isacord 40 1755
4.  Isacord 40 1730
5.  Isacord 40 3820
6.  Isacord 40 3040









12401-17  99 x 55 mm
3.9 x 2.2 inch  1.345



1.  Isacord 40 0731
2.  Isacord 40 0630
3.  Isacord 40 5934
4.  Isacord 40 0111
5.  Isacord 40 4240
6.  Isacord 40 1342



Ck520  75 x 60 mm
3 x 2.4 inch  11.019



1.  Isacord 40 3906
2.  Isacord 40 0132
3. Isacord 40 0015
4.  Yenmet 7003
5.  Isacord 40 3652
6.  Isacord 40 0020
7.  Isacord 40 0600
8.  Isacord 40 2113



Ck510  76 x 60 mm
3 x 2.4 inch  8.069



1. Isacord 40 5934
2. Isacord 40 3840
3. Isacord 40 3901
4. Isacord 40 0108
5. Isacord 40 0015
6. Isacord 40 3622
7. Isacord 40 4174
8. Isacord 40 0015



Ck522  71 x 53 mm
2.8 x 2.1 inch  9.089

1. Isacord 40 3810
2. Isacord 40 0131
3. Isacord 40 0015
4. Isacord 40 0020
5. Isacord 40 0310
6. Isacord 40 1703
7. Yenmet 7021
8. Isacord 40 3353





Ck863  127 x 125 mm
5 x 4.9 inch  19.354

1. Isacord 40 0630
2. Isacord 40 0506
3. Isacord 40 0630
4. Isacord 40 0015
5. Isacord 40 4103
6. Isacord 40 4111
7. Isacord 40 1701
8. Isacord 40 2830
9. Isacord 40 5912
10. Isacord 40 1730
11. Isacord 40 5510
12. Isacord 40 0811
13. Isacord 40 4174
14. Isacord 40 0352
15. Isacord 40 1805
16. Isacord 40 0015
17. Isacord 40 3151





Wish Upon My Star Light

Nb198_48  94 x 72 mm
3.7 x 2.8 inch  9.711

1. Isacord 40 2650
2. Isacord 40 0713
3. Isacord 40 2166
4. Isacord 40 1755
5. Isacord 40 3251
6. Isacord 40 1600
7. Isacord 40 2153
8. Isacord 40 2152
9. Isacord 40 2761





HUG ME!

Be790307  142 x 127 mm
5.6 x 5 inch  19.667

1. Applique 1
2. Applique 3
3. Isacord 40 3130
4. Applique 1
5. Applique 3
6. Isacord 40 0003
7. Isacord 40 1720
8. Isacord 40 0020
9. Isacord 40 0520
10. Isacord 40 3541





Beep Beep!

Be790311  114 x 152 mm
4.5 x 6 inch  12.320

1. Applique 1
2. Applique 3
3. Isacord 40 0933
4. Applique 1
5. Applique 3
6. Applique 1
7. Applique 3
8. Isacord 40 0776
9. Applique 1
10. Applique 3
11. Isacord 40 1900
12. Isacord 40 0176
13. Isacord 40 0015
14. Isacord 40 0020





Be790305  118 x 145 mm
4.6 x 5.7 inch  13.118

1. Isacord 40 0015
2. Applique 1
3. Applique 3
4. Isacord 40 3541
5. Applique 1
6. Applique 3
7. Isacord 40 0345
8. Applique 1
9. Applique 3
10. Isacord 40 1900
11. Isacord 40 0020
12. Isacord 40 0015





Cute

Be790306  132 x 151 mm
5.2 x 6 inch  18.399

1. Isacord 40 0003
2. Applique 1
3. Applique 2
4. Isacord 40 0003
5. Isacord 40 3910
6. Isacord 40 0230
7. Isacord 40 2723
8. Isacord 40 1301
9. Isacord 40 2640
10. Isacord 40 0003
11. Isacord 40 3332





Cute Bee

Be790309  87 x 150 mm
3.4 x 5.9 inch  13.252

1. Applique 1
2. Applique 3
3. Isacord 40 0015
4. Isacord 40 1900
5. Isacord 40 0020
6. Isacord 40 4116
7. Isacord 40 0176
8. Isacord 40 0015
9. Isacord 40 0310



DOG

Be790310  138 x 136 mm
5.4 x 5.4 inch  16.278

1. Applique 1
2. Applique 3
3. Applique 1
4. Applique 3
5. Isacord 40 1161
6. Isacord 40 1141
7. Isacord 40 1161
8. Isacord 40 3654
9. Isacord 40 0176
10. Isacord 40 1141
11. Isacord 40 0020
12. Isacord 40 0015



I LOVE YOU

Be790312 122 x 133 mm 4.8 x 5.2 inch 22.489

1. Applique 1
2. Applique 3
3. Applique 1
4. Applique 3
5. Isacord 40 0015
6. Isacord 40 1600
7. Isacord 40 0108
8. Isacord 40 2912
9. Isacord 40 3600
10. Isacord 40 1141
11. Isacord 40 0020



Be790313 99 x 102 mm 3.9 x 4 inch 8.788

1. Applique 1
2. Applique 3
3. Isacord 40 3750
4. Isacord 40 1114
5. Isacord 40 1900
6. Isacord 40 3620
7. Isacord 40 2510
8. Isacord 40 5324
9. Isacord 40 1114
10. Isacord 40 1060
11. Isacord 40 4114
12. Isacord 40 0020
13. Isacord 40 0015



Ck511 76 x 64 mm 3 x 2.5 inch 6.803

1. Isacord 40 4174
2. Isacord 40 3600
3. Isacord 40 3840
4. Isacord 40 2900

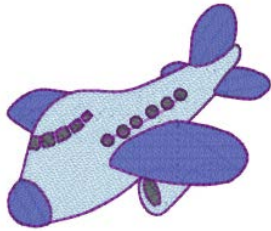

Cm193_48 107 x 127 mm 4.2 x 5 inch 12.461

1. Applique 1
2. Applique 3
3. Applique 1
4. Applique 3
5. Isacord 40 2152
6. Isacord 40 3652
7. Isacord 40 2250
8. Isacord 40 3770
9. Isacord 40 2250
10. Isacord 40 0101



Ck667 100 x 82 mm 3.9 x 3.2 inch 5.568

1. Applique 1
2. Applique 2
3. Applique 3
4. Isacord 40 4103
5. Isacord 40 4610
6. Isacord 40 4220
7. Isacord 40 0015
8. Isacord 40 3544



Ck738 89 x 86 mm 3.5 x 3.4 inch 5.620

1. Isacord 40 3151
2. Isacord 40 3761
3. Isacord 40 2761
4. Isacord 40 1430
5. Isacord 40 0221
6. Isacord 40 5822
7. Isacord 40 0811
8. Isacord 40 0520
9. Isacord 40 1362



Ck970 85 x 82 mm 3.3 x 3.2 inch 16.571

1. Isacord 40 0151
2. Isacord 40 0152
3. Isacord 40 0124
4. Isacord 40 0131
5. Isacord 40 3150
6. Isacord 40 2830
7. Isacord 40 3040
8. Isacord 40 3640
9. Isacord 40 3710
10. Isacord 40 2051
11. Isacord 40 1725
12. Isacord 40 3743
13. Isacord 40 0015
14. Isacord 40 3743



Cm147_48 55 x 100 mm 2.2 x 3.9 inch 6.170

1. Isacord 40 1755
2. Isacord 40 0713
3. Isacord 40 0704
4. Isacord 40 6141
5. Isacord 40 3251
6. Isacord 40 1600



Cm348_48 119 x 167 mm 4.7 x 6.6 inch 22.995



1. Isacord 40 2155
2. Isacord 40 2761
3. Isacord 40 3130
4. Isacord 40 3251
5. Isacord 40 2650
6. Isacord 40 2640
7. Isacord 40 5610
8. Isacord 40 5722
9. Isacord 40 2504
10. Isacord 40 0713
11. Isacord 40 0822





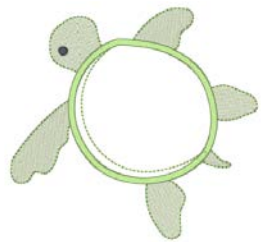





Cm362_48 120 x 113 mm 4.7 x 4.4 inch 6.792

1. Isacord 40 6051
2. Isacord 40 5650
3. Isacord 40 6051
4. Isacord 40 5531
5. Isacord 40 4174
6. Isacord 40 5610



Cm376_48  100 x 97 mm
3.9 x 3.8 inch  2.696

1.  Isacord 40 0703
2.  Isacord 40 0702
3.  Isacord 40 0131
4.  Isacord 40 0713
5.  Isacord 40 0703
6.  Isacord 40 0704
7.  Isacord 40 3971





Nb193_48  113 x 96 mm
4.5 x 3.8 inch  8.079

1.  Isacord 40 2363
2.  Isacord 40 2650
3.  Isacord 40 5912
4.  Isacord 40 1600
5.  Isacord 40 3920
6.  Isacord 40 0821
7.  Isacord 40 2830
8.  Isacord 40 2153





Borders and Lace

21021-25  34 x 71 mm
1.3 x 2.8 inch  4.748



1.  Isacord 40 1252





Oc00303  101 x 110 mm
4 x 4.4 inch  35.018

1. Isacord 40 0015



12659-01  45 x 58 mm
1.8 x 2.3 inch  6.790



1.  Isacord 40 1352
2.  Isacord 40 1430



12659-06  37 x 59 mm
1.4 x 2.3 inch  6.465



1.  Isacord 40 4625
2.  Isacord 40 4515



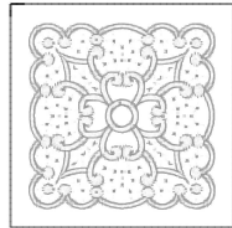

Hg341_48  64 x 64 mm
2.5 x 2.5 inch  5.561

1. Isacord 40 0015
2.  Isacord 40 0020



Nx957  98 x 88 mm
3.9 x 3.5 inch  18.451



1.  Isacord 40 1950





Nx696  91 x 91 mm
3.6 x 3.6 inch  9.346



























































1.  Yenmet 7025





Fb461_48  122 x 121 mm
4.8 x 4.8 inch  7.889

1.  Isacord 40 0020
2.  Isacord 40 1172





<p>12633-20  34 x 170 mm 1.4 x 6.7 inch  12.897</p>	<p>12508-08  40 x 151 mm 1.6 x 5.9 inch  7.102</p>
<p>1. Isacord 40 0015</p> 	<p>1.  Isacord 40 0352 2.  Isacord 40 4752 3.  Isacord 40 0124</p> 
<p>12508-17  42 x 152 mm 1.6 x 6 inch  7.962</p>	<p> Oc33411  24 x 177 mm 0.9 x 7 inch  15.868</p>
<p>1.  Isacord 40 0352 2.  Isacord 40 4752 3.  Isacord 40 5552</p> 	<p>1. Isacord 40 0015</p> 
<p> Oc33416  36 x 128 mm 1.4 x 5 inch  16.090</p>	<p>12485-12  41 x 139 mm 1.6 x 5.5 inch  3.391</p>
<p>1.  Isacord 40 1902 2. Isacord 40 0015</p> 	<p>1.  Isacord 40 1134 2.  Isacord 40 0520 3.  Isacord 40 4240 4.  Isacord 40 4111 5.  Isacord 40 0702 6.  Isacord 40 1430</p> 
<p>21013-29  40 x 152 mm 1.6 x 6 inch  7.569</p>	<p>Be110415  44 x 172 mm 1.7 x 6.8 inch  6.436</p>
<p>1.  Isacord 40 4332</p> 	<p>1.  Isacord 40 6051 2.  Isacord 40 0811 3.  Isacord 40 1921</p> 
<p>Fa981  35 x 142 mm 1.4 x 5.6 inch  3.709</p>	<p>21002-21  21 x 151 mm 0.8 x 5.9 inch  3.176</p>
<p>1.  Isacord 40 1055</p> 	<p>1.  Isacord 40 1252</p> 
<p>21009-29  32 x 152 mm 1.3 x 6 inch  4.649</p>	<p>82005-40  26 x 240 mm 1 x 9.4 inch  8.256</p>
<p>1.  Isacord 40 5210</p> 	<p>1.  Isacord 40 0851</p> 

Na914_48  19 x 120 mm
0.7 x 4.7 inch  4.691

1.  Isacord 40 3151
2.  Isacord 40 3251
3.  Isacord 40 3150





Nb520_48  26 x 176 mm
1 x 6.9 inch  5.146

1.  Isacord 40 0131
2.  Isacord 40 4174





















Fb436_48  29 x 133 mm
1.1 x 5.2 inch  4.735

1.  Isacord 40 3130
2.  Isacord 40 3150
3.  Isacord 40 4240













Seasons

 **Hg746_48**  112 x 138 mm
4.4 x 5.4 inch  17.815

1.  Isacord 40 3040
2.  Applique 1
3.  Applique 2
4.  Isacord 40 0221
5.  Applique 1
6.  Applique 2
7.  Isacord 40 0142
8.  Isacord 40 0108
9.  Applique 1
10.  Applique 2
11.  Isacord 40 0800
12.  Isacord 40 0020
13.  Isacord 40 1200
14.  Isacord 40 0020
15.  Isacord 40 0670
16.  Isacord 40 0142











Nb754_48  114 x 128 mm
4.5 x 5 inch  13.084

1.  Yenmet 7037
2.  Isacord 40 2155
3.  Isacord 40 0651
4.  Isacord 40 0101
5.  Isacord 40 2532
6.  Isacord 40 0640
7.  Isacord 40 1352
8.  Yenmet 7030
9.  Isacord 40 0232
10.  Isacord 40 1123









 **21019-14**  123 x 130 mm
4.8 x 5.1 inch  23.294



1.  Isacord 40 1805
2.  Isacord 40 1805
3.  Isacord 40 1805
4.  Isacord 40 1912
5.  Isacord 40 0138
6.  Isacord 40 0020
7.  Isacord 40 0131
8.  Isacord 40 0015
9.  Isacord 40 0138
10.  Isacord 40 1805





Hg795_48  89 x 164 mm
3.5 x 6.5 inch  3.453

1.  Isacord 40 5730
2.  Isacord 40 5513
3.  Isacord 40 4430
4.  Isacord 40 1032
5.  Isacord 40 1900
6.  Isacord 40 4113





 **12597-16**  88 x 85 mm
3.5 x 3.3 inch  15.862

1.  Isacord 40 0904
2.  Isacord 40 0940



80009-17  86 x 130 mm
3.4 x 5.1 inch  6.582

1.  Isacord 40 5934
2.  Isacord 40 5866
3.  Isacord 40 5934



He255 133 x 127 mm 5.2 x 5 inch 17.198

- 1. Isacord 40 0111
- 2. Isacord 40 1701
- 3. Isacord 40 1800
- 4. Isacord 40 1701
- 5. Isacord 40 1800
- 6. Isacord 40 2640
- 7. Isacord 40 5650
- 8. Isacord 40 5610
- 9. Isacord 40 0015
- 10. Isacord 40 0111
- 11. Isacord 40 1060
- 12. Isacord 40 3910
- 13. Isacord 40 0800
- 14. Isacord 40 0940
- 15. Isacord 40 0651
- 16. Isacord 40 0832
- 17. Isacord 40 0651
- 18. Isacord 40 0832
- 19. Isacord 40 3650
- 20. Isacord 40 1351
- 21. Isacord 40 0108



He252 88 x 145 mm 3.5 x 5.7 inch 12.251

- 1. Isacord 40 1902
- 2. Isacord 40 1701
- 3. Isacord 40 1902
- 4. Isacord 40 0532
- 5. Isacord 40 0842
- 6. Isacord 40 0532
- 7. Isacord 40 0842
- 8. Isacord 40 1902
- 9. Isacord 40 0651
- 10. Isacord 40 1123
- 11. Isacord 40 5220
- 12. Isacord 40 5210
- 13. Isacord 40 5422
- 14. Isacord 40 0101
- 15. Isacord 40 1430
- 16. Isacord 40 1725
- 17. Isacord 40 0520
- 18. Isacord 40 0824
- 19. Isacord 40 3910
- 20. Isacord 40 3650
- 21. Isacord 40 3910
- 22. Isacord 40 1902
- 23. Isacord 40 3650
- 24. Isacord 40 1123
- 25. Isacord 40 5324
- 26. Isacord 40 1154



Hg747_48 124 x 147 mm 4.9 x 5.8 inch 18.378

- 1. Isacord 40 0970
- 2. Isacord 40 3770
- 3. Isacord 40 5912
- 4. Isacord 40 0520
- 5. Isacord 40 0811
- 6. Isacord 40 3350
- 7. Isacord 40 3040
- 8. Applique 1
- 9. Applique 2
- 10. Applique 1
- 11. Applique 2
- 12. Applique 1
- 13. Applique 2
- 14. Isacord 40 4073
- 15. Isacord 40 0020
- 16. Isacord 40 1200
- 17. Isacord 40 0101



Nb759_48 99 x 62 mm 3.9 x 2.4 inch 4.937

- 1. Yenmet 7037
- 2. Isacord 40 0640
- 3. Isacord 40 1352
- 4. Isacord 40 0232
- 5. Isacord 40 1123



Hd976 101 x 108 mm 4 x 4.3 inch 18.674

- 1. Isacord 40 3962
- 2. Yenmet 7029
- 3. Isacord 40 0640
- 4. Isacord 40 0824
- 5. Isacord 40 0015
- 6. Isacord 40 0020
- 7. Isacord 40 0142
- 8. Isacord 40 3962
- 9. Isacord 40 0020
- 10. Isacord 40 0934
- 11. Isacord 40 0640
- 12. Isacord 40 0824
- 13. Isacord 40 5650
- 14. Isacord 40 5531
- 15. Isacord 40 1220
- 16. Isacord 40 5822
- 17. Isacord 40 5531
- 18. Isacord 40 0015
- 19. Isacord 40 5822



Hg806_48 28 x 170 mm 1.1 x 6.7 inch 4.988

- 1. Isacord 40 2530
- 2. Isacord 40 1900
- 3. Isacord 40 5730
- 4. Isacord 40 1114
- 5. Isacord 40 4430
- 6. Isacord 40 4113



12415-32 80 x 191 mm 3.1 x 7.5 inch 10.937

- 1. YLI variations 8019















































































12415-29 108 x 172 mm 4.3 x 6.8 inch 4.814



- 1. YLI variations 8019



Overview Stitch Patterns



12433-05  83 x 124 mm 3.3 x 4.9 inch  15.348	12417-04  84 x 97 mm 3.3 x 3.8 inch  8.085
<ol style="list-style-type: none"> 1.  Isacord 40 1725 2.  Isacord 40 5934 3.  Isacord 40 0442 4.  Isacord 40 2115 5.  Isacord 40 2711 	<ol style="list-style-type: none"> 1.  Isacord 40 1010 2.  Isacord 40 0811 3.  Isacord 40 1311 4.  Isacord 40 1543 
Be790303  70 x 70 mm 2.7 x 2.8 inch  5.764	He962_48  120 x 135 mm 4.7 x 5.3 inch  4.128
<ol style="list-style-type: none"> 1.  Isacord 40 0532 2.  Isacord 40 1300 3.  Isacord 40 0020 4.  Isacord 40 0015 	<ol style="list-style-type: none"> 1.  Isacord 40 1902 
12421-11  40 x 43 mm 1.6 x 1.7 inch  3.965	12421-37  67 x 61 mm 2.6 x 2.4 inch  1.320
<ol style="list-style-type: none"> 1.  Isacord 40 0800 2.  Isacord 40 0904 3.  Isacord 40 0020 4.  Isacord 40 0015 	<ol style="list-style-type: none"> 1.  Isacord 40 0020 
12421-03  46 x 48 mm 1.8 x 1.9 inch  2.328	Cm287_48  90 x 117 mm 3.6 x 4.6 inch  18.749
<ol style="list-style-type: none"> 1.  Isacord 40 0020 2.  Isacord 40 0015 3.  Isacord 40 0111 	<ol style="list-style-type: none"> 1.  Isacord 40 0870 2.  Isacord 40 1172 3.  Isacord 40 0934 4.  Isacord 40 1755 5.  Isacord 40 0020 6.  Isacord 40 5531 7.  Isacord 40 5610 8.  Isacord 40 5722 9.  Isacord 40 2550 10.  Isacord 40 0015 11.  Isacord 40 0713 12.  Isacord 40 1840 13.  Isacord 40 1921 14.  Isacord 40 2241 
Cm426_48  46 x 96 mm 1.8 x 3.8 inch  2.047	Fq749_48  78 x 95 mm 3.1 x 3.7 inch  5.765
<ol style="list-style-type: none"> 1.  Isacord 40 0761 2.  Isacord 40 2155 3.  Isacord 40 1725 4.  Isacord 40 1902 5.  Isacord 40 0010 	<ol style="list-style-type: none"> 1.  Isacord 40 1114 2.  Isacord 40 1335 3.  Isacord 40 5664 

He919_48  89 x 69 mm
3.5 x 2.7 inch  5.245

1.  Isacord 40 3650
2.  Isacord 40 3840
3.  Isacord 40 3641



Hg053_48  122 x 122 mm
4.8 x 4.8 inch  15.370

1.  Isacord 40 5531
2.  Isacord 40 5643
3.  Isacord 40 1805









Hg319_48  89 x 151 mm
3.5 x 6 inch  8.681

1.  Isacord 40 5822





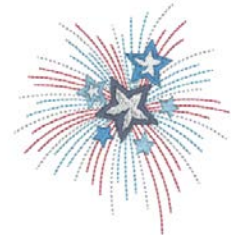

Hg460_48  92 x 98 mm
3.6 x 3.9 inch  7.166

1.  Isacord 40 3650
2.  Isacord 40 0015
3.  Isacord 40 1921
4.  Isacord 40 3840
5.  Isacord 40 3810
6.  Isacord 40 4071
7.  Isacord 40 3444



Nb317_48  87 x 87 mm
3.4 x 3.4 inch  2.064

1.  Isacord 40 0020
2.  Isacord 40 0600
3.  Isacord 40 0800
4.  Isacord 40 0020



Na617  96 x 96 mm
3.8 x 3.8 inch  2.642

1.  Isacord 40 3543

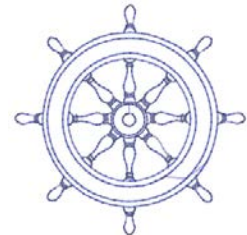

Na592  114 x 51 mm
4.5 x 2 inch  1.939

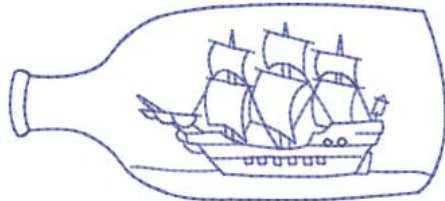

1.  Isacord 40 3543



Nc009_48  18 x 94 mm
0.7 x 3.7 inch  936

1.  Isacord 40 3641







Na597  57 x 53 mm
2.2 x 2.1 inch  920

1.  Isacord 40 3543



Nb036_48  36 x 70 mm
1.4 x 2.8 inch  3.909

1.  Isacord 40 3770
2.  Isacord 40 0131
3.  Isacord 40 0622
4.  Isacord 40 0015







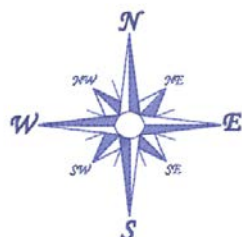



































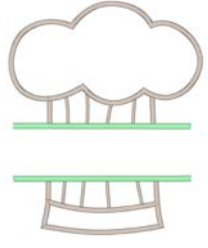





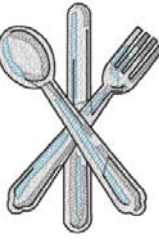



























Na614  102 x 101 mm
4 x 4 inch  2.867



1.  Isacord 40 3543



Sport and Hobbies







<p>12472-01  138 x 142 mm 5.4 x 5.6 inch  23.233</p> <ol style="list-style-type: none"> 1.  Isacord 40 2504 2.  Isacord 40 3901 3.  Isacord 40 5610 4.  Isacord 40 4240 5.  Isacord 40 0015 6.  Isacord 40 0015 7.  Isacord 40 1123 8.  Isacord 40 0761 9.  Isacord 40 1902 10.  Isacord 40 2504 11.  Isacord 40 3901 12.  Isacord 40 5610 13.  Isacord 40 4240 14.  Isacord 40 1300 	<p>12611-08  80 x 120 mm 3.1 x 4.7 inch  5.770</p> <ol style="list-style-type: none"> 1.  Applique 1 2.  Applique 2 3.  Applique 1 4.  Applique 2 5.  Isacord 40 1154 6.  Isacord 40 5440 7.  Isacord 40 1902 
<p>12611-18  130 x 158 mm 5.1 x 6.2 inch  8.045</p> <ol style="list-style-type: none"> 1.  Applique 1 2.  Applique 2 3.  Isacord 40 0151 4.  Isacord 40 5440 	<p>Nx737  72 x 99 mm 2.8 x 3.9 inch  10.793</p> <ol style="list-style-type: none"> 1.  Isacord 40 0015 2.  Yenmet 7005 3.  Isacord 40 3962 4.  Isacord 40 0020 
<p>82014-28  142 x 117 mm 5.6 x 4.6 inch  26.582</p> <ol style="list-style-type: none"> 1.  Applique 1 2.  Applique 2 3.  Isacord 40 0105 4.  Isacord 40 0020 5.  Isacord 40 4073 6.  Isacord 40 1902 	<p>12383-18  91 x 171 mm 3.6 x 6.7 inch  5.182</p> <ol style="list-style-type: none"> 1.  Isacord 40 4174 
<p>Sp980  63 x 64 mm 2.5 x 2.5 inch  11.286</p> <ol style="list-style-type: none"> 1.  Isacord 40 0015 2.  Isacord 40 0142 3.  Isacord 40 0020 	<p>Be790606  100 x 86 mm 3.9 x 3.4 inch  7.445</p> <ol style="list-style-type: none"> 1.  Isacord 40 0020 2.  Isacord 40 1306 
<p>Be790608  80 x 80 mm 3.2 x 3.1 inch  7.937</p> <ol style="list-style-type: none"> 1.  Isacord 40 0020 	<p>Be790603  80 x 75 mm 3.2 x 2.9 inch  11.824</p> <ol style="list-style-type: none"> 1.  Isacord 40 0015 2.  Isacord 40 3654 

Be790602  80 x 75 mm
3.1 x 3 inch  10.169

1.  Isacord 40 5643
2.  Isacord 40 5912
3.  Isacord 40 0015







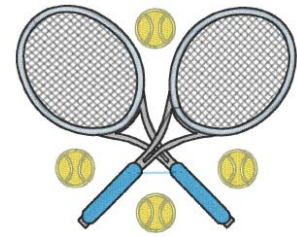



Sp989  102 x 82 mm
4 x 3.2 inch  10.827

1.  Isacord 40 4174
2.  Isacord 40 0142
3.  Isacord 40 3901
4.  Isacord 40 3962
5.  Isacord 40 0506
6.  Isacord 40 0520
7.  Isacord 40 0020







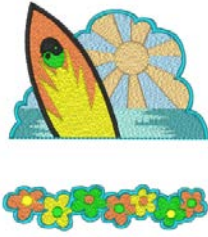





Sr067  87 x 97 mm
3.4 x 3.8 inch  16.143

1.  Isacord 40 3910
2.  Isacord 40 0706
3.  Isacord 40 4531
4.  Isacord 40 4430
5.  Isacord 40 1106
6.  Isacord 40 0501
7.  Isacord 40 5500
8.  Isacord 40 0020
9.  Isacord 40 4010











Fb148_48  101 x 89 mm
4 x 3.5 inch  11.163

1.  Isacord 40 0131
2.  Isacord 40 0608
3.  Isacord 40 0941
4.  YLI variations 8016
5.  YLI variations 8007
6.  Isacord 40 1123
7.  Isacord 40 1172
8.  Isacord 40 1725
9.  Isacord 40 6141
10.  Isacord 40 0142
11.  Isacord 40 2810









Sr589  95 x 66 mm
3.7 x 2.6 inch  14.868

1.  Isacord 40 0142
2.  Isacord 40 1220
3.  Isacord 40 1332
4.  Isacord 40 1334
5.  Isacord 40 3611
6.  Isacord 40 1800
7.  Isacord 40 0015
8.  Isacord 40 4174













Rc244  88 x 53 mm
3.5 x 2.1 inch  12.558



1.  Isacord 40 0020
2.  Isacord 40 3600
3.  Isacord 40 4230
4.  Yenmet 7005
5.  Isacord 40 3910
6.  Isacord 40 1902
7.  Isacord 40 1912
8.  Isacord 40 0108
9.  Isacord 40 0020
10.  Isacord 40 0015
11.  Isacord 40 0124





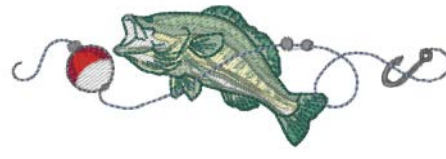









Sr551  120 x 38 mm
4.7 x 1.5 inch  6.859

1.  Isacord 40 1902
2.  Isacord 40 2123
3.  Isacord 40 0015
4.  Isacord 40 0520
5.  Isacord 40 5664
6.  Isacord 40 5233
7.  Isacord 40 5374
8.  Yenmet 7032
9.  Isacord 40 0111
10.  Yenmet 7036







80085-25  135 x 166 mm
5.3 x 6.5 inch  14.361

1.  Isacord 40 0015
2.  Isacord 40 0015
3.  Isacord 40 0015
4.  Isacord 40 0015
5.  Isacord 40 0020
6.  Isacord 40 0112
7.  Isacord 40 0142
8.  Isacord 40 0142
9.  Isacord 40 4620
10.  Isacord 40 0142
11.  Isacord 40 0015
12.  Isacord 40 1906
13.  Isacord 40 0020







Animals

Wp415_48  132 x 148 mm
5.2 x 5.8 inch  25.110

1.  Isacord 40 0941
2.  Isacord 40 0532
3.  Isacord 40 0945
4.  Isacord 40 0020











Wp421_48  96 x 137 mm
3.8 x 5.4 inch  14.219

1.  Isacord 40 1161
2.  Isacord 40 1876
3.  Isacord 40 1154













Overview Stitch Patterns

Cm213_48  58 x 102 mm
2.3 x 4 inch  7.866

1.  Isacord 40 1840
2.  Isacord 40 1055
3.  Isacord 40 1252
4.  Isacord 40 0651
5.  Isacord 40 0660
6.  Isacord 40 0020
7.  Isacord 40 1055















Na248  78 x 73 mm
3.1 x 2.9 inch  10.132

1.  Isacord 40 0101
2.  Isacord 40 3971
3.  Isacord 40 2220
4.  Isacord 40 0132
5.  Isacord 40 2051
6.  Isacord 40 2155
7.  Isacord 40 2320
8.  Isacord 40 2220
9.  Yenmet 7023











Hd977  98 x 98 mm
3.8 x 3.9 inch  13.738



1.  Isacord 40 3962
2.  Isacord 40 0015
3.  Isacord 40 0640
4.  Isacord 40 0824
5.  Isacord 40 2650
6.  Isacord 40 0020
7.  Isacord 40 0142
8.  Isacord 40 0640
9.  Isacord 40 0824
10.  Isacord 40 2650
11.  Isacord 40 2830
12.  Isacord 40 1352
13.  Yenmet 7029











Lj598  106 x 81 mm
4.2 x 3.2 inch  15.746

1.  Isacord 40 0101
2.  Isacord 40 0131
3.  Isacord 40 0132
4.  Isacord 40 4174
5.  Isacord 40 0108
6.  Isacord 40 0020
7.  Isacord 40 5933
8.  Isacord 40 0453







Cm220_48  71 x 72 mm
2.8 x 2.8 inch  7.571

1.  Isacord 40 1755
2.  Isacord 40 0101
3.  Isacord 40 0142
4.  Isacord 40 0101
5.  Isacord 40 4071
6.  Isacord 40 0142
7.  Isacord 40 0934
8.  Isacord 40 0020





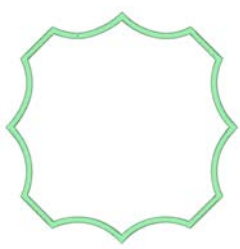

Frames

12611-27  137 x 137 mm
5.4 x 5.4 inch  3.961

1.  Applique 1
2.  Applique 2
3.  Isacord 40 5440







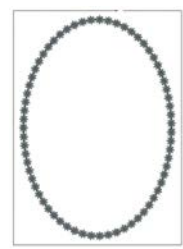

32078-04  123 x 173 mm
4.9 x 6.8 inch  1.978

1.  Isacord 40 0020
2.  Isacord 40 4174
3.  Isacord 40 0020
4.  Isacord 40 4174



12630-07  120 x 205 mm
4.7 x 8.1 inch  6.820

1.  Isacord 40 1030
2.  Isacord 40 1030
3.  Isacord 40 1030
4.  Isacord 40 1030
5.  Isacord 40 1030
6.  Isacord 40 1030

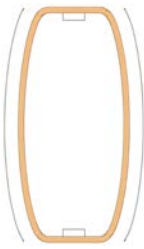

12611-28  140 x 140 mm
5.5 x 5.5 inch  3.649

1.  Applique 1
2.  Applique 2
3.  Isacord 40 0703

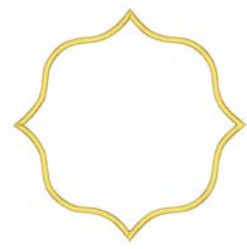

12649-05 91 x 88 mm 3.6 x 3.5 inch 9.087

1. Applique 1
2. Applique 2
3. Isacord 40 1840
4. Isacord 40 1860
5. Isacord 40 0015



12606-26 139 x 139 mm 5.5 x 5.5 inch 5.211

1. Isacord 40 0670
2. Isacord 40 0670
3. Isacord 40 0670



12606-33 43 x 70 mm 1.7 x 2.8 inch 2.376

1. Isacord 40 0670
2. Isacord 40 0670
3. Isacord 40 0670



12606-37 46 x 78 mm 1.8 x 3.1 inch 2.692

1. Isacord 40 0670
2. Isacord 40 0670
3. Isacord 40 0670



32078-02 123 x 173 mm 4.9 x 6.8 inch 1.181

1. Isacord 40 0020
2. Isacord 40 4174
3. Isacord 40 0020
4. Isacord 40 4174



32078-03 123 x 173 mm 4.9 x 6.8 inch 1.264

1. Isacord 40 0020
2. Isacord 40 4174
3. Isacord 40 0020
4. Isacord 40 4174

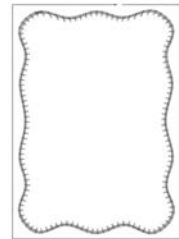

Nz195 77 x 77 mm 3 x 3 inch 15.343

1. Isacord 40 0660
2. Isacord 40 0713
3. Isacord 40 2153
4. Isacord 40 1362
5. Isacord 40 0870
6. Isacord 40 2830
7. Isacord 40 1725
8. Isacord 40 4071

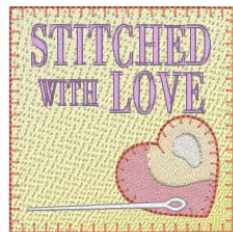

12611-21 156 x 72 mm 6.1 x 2.8 inch 11.513

1. Applique 1
2. Applique 2
3. Isacord 40 1703



12611-23 156 x 72 mm 6.1 x 2.8 inch 12.817

1. Applique 1
2. Applique 2
3. Isacord 40 1902



12611-22 156 x 72 mm 6.1 x 2.8 inch 12.504

1. Applique 1
2. Applique 2
3. Isacord 40 1703

































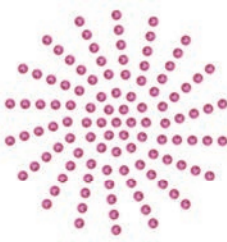













































12611-24 156 x 72 mm 6.1 x 2.8 inch 12.613

1. Applique 1
2. Applique 2
3. Isacord 40 1902



DesignWorks

 12448-11_cr  84 x 124 mm 3.3 x 4.9 inch  174	 12448-09_pw  121 x 161 mm 4.8 x 6.3 inch  8.265
<ol style="list-style-type: none"> 1.  Swarovski 0280 2.  Swarovski 0280 3.  Swarovski 0280 	<ol style="list-style-type: none"> 1.  Edding 10 2.  Edding 2 3.  Edding 8 4.  Edding 1 
 Dw11  70 x 71 mm 2.8 x 2.8 inch  110	 21026-08_dw  86 x 174 mm 3.4 x 6.9 inch  11.047
<ol style="list-style-type: none"> 1.  Swarovski 0502 	<ol style="list-style-type: none"> 1.  Edding 69 2.  Isacord 40 0020 
 21026-02_dw  69 x 194 mm 2.7 x 7.6 inch  7.815	 21026-02_cr  104 x 127 mm 4.1 x 5 inch  150
<ol style="list-style-type: none"> 1.  Edding 69 2.  Applique 1 3.  Applique 2 4.  Isacord 40 0015 5.  Isacord 40 0020 6.  Isacord 40 0015 	<ol style="list-style-type: none"> 1.  Swarovski 0280 2.  Swarovski 0280 
 21026-05_dw  118 x 202 mm 4.6 x 7.9 inch  9.309	 12448-08_pw  119 x 177 mm 4.7 x 7 inch  4.540
<ol style="list-style-type: none"> 1.  Edding 9 2.  Isacord 40 0020 	<ol style="list-style-type: none"> 1.  Edding 7 
 21022-13_dw  106 x 193 mm 4.2 x 7.6 inch  15.285	 Dw07  114 x 152 mm 4.5 x 6 inch  198
<ol style="list-style-type: none"> 1.  Edding 34 2.  Edding 68 3.  Edding 6 4.  Applique 1 5.  Applique 2 6.  Isacord 40 2640 7.  Applique 1 8.  Applique 2 9.  Isacord 40 1352 10.  Isacord 40 1600 11.  Isacord 40 4111 12.  Isacord 40 4103 13.  Isacord 40 0017 14.  Isacord 40 2830 	<ol style="list-style-type: none"> 1.  Swarovski 0237 

Dw05 105 x 94 mm 4.1 x 3.7 inch 13.334

1. ■ Isacord 40 2022
2. ■ Cut 0001
3. ■ Cut 0002
4. ■ Cut 0003
5. ■ Cut 0004
6. ■ Isacord 40 2022



Dw10 184 x 184 mm 7.3 x 7.3 inch 5.939

1. ■ Cut 0001
2. ■ Cut 0002
3. ■ Cut 0003
4. ■ Cut 0004



Be700121 128 x 128 mm 5 x 5 inch 2.183

1. ■ Isacord 40 3600
2. ■ Isacord 40 1703



Be700122 119 x 37 mm 4.7 x 1.5 inch 4.124

1. ■ Isacord 40 5833



Be700123 113 x 206 mm 4.4 x 8.1 inch 6.090

1. ■ Punch 0004
2. ■ Punch 0007

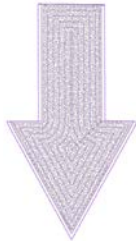

Be700124 141 x 134 mm 5.6 x 5.3 inch 6.184

1. ■ Isacord 40 2300
2. ■ Isacord 40 3901



Index

A

Activate/Deactivate Functions.....	24
Activating the Audio Signals	56
Activating the Bobbin Thread Indicator	55
Activating the Upper Thread Indicator	55
Adjust Values.....	24
Adjusting the Brightness of the Display	56
Adjusting the Maximum Sewing Speed	48
Adjusting the Presser Foot Position via the Knee Lifter of the Free Hand System.....	36
Adjusting the Sewing Light	57
Adjusting the Upper Thread Tension	48
Alphabets	96
Altering the Embroidery Design Size Disproportionally.....	136
Altering the Embroidery Design Size Proportionally	135
Altering the Stitch Density.....	137
Attach the BSR Presser Foot	113
Attaching the Hoop	129
Attaching the Knee Lifter of the Free Hand System	32
Attaching the Module.....	122
Attaching the Stitch Plate.....	125

B

Back to Basic Setting.....	58
BERNINA Dual Feed.....	62
Buttonholes	98

C

Calibrating the Buttonhole Foot with Slide #3A.....	59
Calibrating the Embroidery Hoop.....	52
Calling Up the Creative Consultant	61
Calling Up the Help.....	61
Calling Up the Tutorial	61
Changing the Color	142
Changing the Needle.....	37
Changing the Presser Foot	36
Changing the Stitch Plate.....	39
Checking the Firmware Version.....	150
Child Safety Lock	61
Cleaning the Feed Dog	151
Cleaning the Hook.....	152
Cleaning the Thread Catcher	154
Combination Mode.....	66, 139
Combining Embroidery Designs	139

Cord.....	101
Creating Lettering.....	141

D

Decorative Stitches	90
Dispose of the Machine	163

E

Editing the Lettering	141
Embroidery file format	119
Embroidery Test.....	119
Energy-saving Mode	61
Entering Dealer Data.....	57
Environmental Protection.....	11
Error Messages	155
Explanation of Symbols.....	12

F

Firmware	
Activate/Deactivate Functions.....	24
Adjust Values.....	24
Navigation	23
Foot Control	33
Connecting	31

I

Inserting the Embroidery Needle	124
Inserting the Spool Cap	34

L

Lubricating the Hook	152
----------------------------	-----

M

Maintenance and Cleaning	151
Moving the hoop to the Back	130
Moving the Module for the Sewing Mode	130

N

Navigation	23
Needle Stop Up/Down (Permanent).....	39
Needle Up/Down	
via the Foot Control	33
Needle, Thread, Fabric	25
Needle/Thread Combination	29
Needles Overview	26



BERNINA recommends threads from *Mettler*[®]

BERNINA International AG | CH-8266 Steckborn Switzerland | www.bernina.com | © Copyright by BERNINA International AG

made to create **BERNINA**

1028835_30A.04
2023-08 EN